



City of Miami Gardens INVITATION TO BID

The City of Miami Gardens acting as lead City for the SE Fla. Co-Op Group is requesting sealed bids from qualified contractors for the replacement and installation of new sidewalks on an as needed basis.

BID SUBMISSION:

Bids will be received by sealed envelope in the Procurement Department, City of Miami Gardens. **If Delivered by mail send to:** Procurement Department, 1515 N.W. 167th Street; Bldg. 5, Suite 200, Miami Gardens, Florida 33169. **If Delivered in person:** Procurement Department location, 1515 NW 167th Street; Bldg. 7, Suite 440 until 2:00 P.M. on **Thursday, August 5, 2010**, at which time they will be opened and read in the Council Chambers by the Procurement Manager. Bids received after this time will not be considered and no time extensions will be permitted. Please clearly mark bids:

“ITB# 09-10-069 – SIDEWALK REPLACEMENTS & INSTALLATION – ANNUAL CONTRACT”

Copies of this Proposal Document may be obtained by contacting DemandStar by Onvia at www.demandstar.com or call toll free 1-800-711-1712 and request Document #09-10-069 or may be found on the City's web site at www.miamigardens-fl.gov. Vendors who obtain specifications and plans from other sources other than DemandStar.com are cautioned that the bid package may be incomplete. All addendums will be posted and disseminated by DemandStar.

FOR INFORMATION

For information on this Invitation to Bid, contact the Procurement Department, (305) 622-8000. Deadline for submittal of questions is **July 22, 2010 @ 3:00 p.m.**

ACCEPTANCE AND REJECTIONS

The City of Miami Gardens reserves the right to reject any or all Proposals with or without cause; to waive any or all irregularities with regard to the specifications and to make the award to the Consultant offering the greatest advantage to the City.

Please be advised that Pursuant to City Ordinance 2008-03-139 “Cone of Silence”, public notice is hereby given that a Cone of Silence is imposed concerning this City's competitive purchasing process, which generally prohibits communications concerning the RFP until such time as the City Manager makes a written communications concerning the competitive purchase transaction. Please see the detailed specifications for the public solicitation for services for a statement fully disclosing the requirements of the “Cone of Silence”.



SOUTHEAST FLORIDA GOVERNMENTAL PURCHASING COOPERATIVE

TO OUR PROSPECTIVE CONTRACTORS:

The attached Invitation for Bid or Request for Proposal represents a cooperative procurement for the Southeast Florida Governmental Purchasing Cooperative.

For the past several years, approximately twenty-six (26) government entities have participated in Cooperative Purchasing in Southeast Florida. The Southeast Florida Governmental Purchasing Cooperative was formed in an effort to provide cost savings and cost avoidances to all entities by utilizing the buying power of combined requirements for common, basic items.

The Government Agencies participating in this particular procurement and their respective delivery locations are listed in the attached document.

Southeast Florida Governmental Purchasing Cooperative Procurement Operational Procedures:

- All questions concerning this procurement should be addressed to the issuing City, hereinafter referred to as the "lead City". All responses are to be returned in accordance with the instructions contained in the attached document. Any difficulty with participating agencies referenced in this award must be brought to the attention of the lead City.
- Each participating governmental entity will be responsible for awarding the contract, issuing its own purchase orders, and for order placement. Each entity will require separate billings, be responsible for payment to the Contractor(s) awarded this contract, and issue its own tax exemption certificates as required by the Contractor.
- The Contract/purchase order terms of each entity will prevail for the individual participating entity. Invoicing instructions, delivery locations and insurance requirements will be in accordance with the respective City requirements.
- Any reference in the documents to a single entity or location will, in fact, be understood as referring to all participating entities referenced in the documents and cover letter unless specifically noted otherwise.
- The awarded Contractor(s) shall be responsible for advising the lead City of those participants who fail to place orders as a result of this award during the contract period.
- The Contractor(s) shall furnish the Lead City a detailed Summary of Sales semi-annually during the contract period. Sales Summary shall include contract number(s), contractor's name, the total of each commodity sold during the reporting period and the total dollar amount of purchases by commodity.
- Municipalities and other governmental entities which are not members of the Southeast Florida Governmental Purchasing Cooperative are strictly prohibited from utilizing any contract or purchase order resulting from this bid award. However, other Southeast Florida Governmental Purchasing Cooperative members may participate in their contract for new usage, during the contract term, or in any contract extension term, if approved by the lead City. New Southeast Florida Governmental Purchasing Cooperative members may participate in any contract on acceptance and approval by the lead City.

- None of the participating governmental entities shall be deemed or construed to be a party to any contract executed by and between any other governmental entity and the Contractor(s) as a result of this procurement action.

“WORKING TOGETHER TO REDUCE COSTS”

SIDEWALK REPLACEMENT & INSTALLATION – ANNUAL CONTRACT
ITB#09-10-069
August 5, 2010

1.0 GENERAL CONDITIONS

1.1 SEALED BIDS:

Original copy of Bid Form as well as any other pertinent documents must be returned in order for the Bid to be considered for award. All Bids are subject to the conditions specified herein and on the attached Special Conditions, Specifications and Bid Form.

The completed Bid must be submitted in a sealed envelope clearly marked with the Bid Title to the Procurement Department, City of Miami Gardens, 1515 N W 167th Street; Bldg 5 Suite 200, if by mail, and Bldg 7, Suite 440, if in person, Miami Gardens, Florida 33169 until 2:00 p.m., local time on date due.

1.2 EXECUTION OF BID:

The Bid must contain a manual signature of an authorized representative in the space provided on the Bid Form. Failure to properly sign Bid shall invalidate same and it shall NOT be considered for award. All Bids must be completed in pen or be typewritten. No erasures are permitted. If a correction is necessary draw a single line through the entered figure and enter the corrected figure above it. Corrections must be initialed by the person signing the Bid. Any illegible entries, pencil Bids or corrections not initialed will not be tabulated. The original Bid conditions and specifications together with bidder's response CANNOT be changed or altered in any way after submitted to the City.

1.3 PRICES QUOTED:

Deduct trade discounts and quote firm net prices. Give both unit price and extended total, when requested. Prices must be stated in units of quantity specified in the Bid specifications. In case of discrepancy in computing the amount of the Bid, the UNIT PRICE quoted will govern. All prices must be F.O.B. destination, freight prepaid (unless otherwise stated in special conditions). Bidders are to list discounts to be given the City for prompt payment. Award, if made, will be in accordance with terms and conditions stated herein. Each item must be proposed separately and no attempt is to be made to tie any item or items in with any other item or items. Cash or quantity discounts offered will not be a consideration in determination of award of Bid(s). All prices quoted shall be guaranteed for 90 days from Bid date unless otherwise specified in Special Conditions.

1.3.1 TAXES:

The City of Miami Gardens is exempt from all Federal Excise and State taxes. The applicable tax exemption number is shown on the Purchase Order.

1.3.2 MISTAKES:

Bidders are expected to examine the specifications, delivery schedules, Bid prices and extensions and all instructions pertaining to supplies and services. Failure to do so will be at the bidder's risk.

1.3.3 UNDERWRITERS' LABORATORIES:

Unless otherwise stipulated in the Bid, all manufactured items and fabricated assemblies shall be U.L. listed or re-examination listing where such has been established by U.L. for the item(s) offered and furnished.

1.3.4 BID'S CONDITIONS:

The City reserves the right to waive irregularities in Bids or to reject all Bids or any part of any Bid deemed necessary for the best interest of the City of Miami Gardens, Florida.

1.4 EQUIVALENTS:

If bidder offers makes of equipment or brands of supplies other than those specified, it must be indicated in the Bid. Specific article(s) of equipment/supplies shall conform in quality, design and construction with all published claims of the manufacturer.

Brand Names: Catalog numbers, manufacturers' and brand names, when listed, are informational guides as to a standard of acceptable product quality level only and should not be construed as an endorsement or a product limitation of recognized and legitimate manufacturers. Bidders shall formally substantiate and verify that product(s) offered conform with or exceed quality as listed in the specifications.

Bidder shall indicate on the Bid form the manufacturers' name and number if proposing other than the specified brands, and shall indicate ANY deviation from the specifications as listed. Other than specified items offered requires complete descriptive technical literature marked to indicate detail(s) conformance with specifications and **MUST BE INCLUDED WITH THE BID. NO BIDS WILL BE CONSIDERED WITHOUT THIS DATA.**

Lacking any written indication of intent to quote an alternate brand or model number, the Bid will be considered as a Bid in complete compliance with the specifications as listed on the attached form.

1.5 NON-CONFORMANCE TO CONTRACT CONDITIONS:

Items may be tested for compliance with specifications. Any item delivered, not conforming to specifications, may be rejected and returned at bidder's expense. These items and items not delivered as per delivery date in Bid and/or purchase order may be purchased on the open market. Any increase in cost may be charged against the bidder. Any violation of these stipulations may also result in Bidder's Name being removed from the vendor list.

1.6 SAMPLES:

Samples of items, when required, must be furnished free of expense and, if not destroyed, will, upon request, be returned at the bidder's expense. Bidders will be responsible for the removal of all samples furnished within (30) days after Bid opening. All samples will be disposed of after thirty (30) days. Each individual sample must be labeled with bidder's name. Failure of bidder to either deliver required samples or to clearly identify samples may be reason for rejection of the Bid. Unless otherwise indicated, samples should be delivered to the Procurement Department, 1515 N W 167th Street; Bldg. 5 Suite 200, if by mail and Bldg 7, Suite 440 if in person, Miami Gardens, Florida 33169.

1.7 DELIVERY:

Unless actual date of delivery is specified (or if specified delivery cannot be met), show number of days (in calendar days) required to make delivery after receipt of purchase order, in space provided. Delivery time may become a basis for making an award. Delivery shall be within the normal working hours of the City, Monday through Friday, excluding holidays.

1.8 INTERPRETATIONS:

Unless otherwise stated in the Bid, any questions concerning conditions and specifications should be submitted in writing to the Procurement Manager, 1515 N W 167th Street; Bldg. 5 Suite 200, Miami Gardens, Florida 33169 Facsimile (305) 474-1285.

1.9 AWARDS:

The City of Miami Gardens reserves the right to reject any and all Bids or any portion of any Bid deemed necessary in the best interest of the City; to accept any item or group of items; to acquire additional quantities at prices quoted on the Bid Form unless additional quantities are not acceptable, in which case the Bid Form must be noted "BID IS FOR SPECIFIED QUANTITY ONLY". The City also reserves the right to award the contract on a split order basis, lump sum basis, individual item basis, or such combination as shall best serve the interest of the City. All awards made as a result of this Bid shall conform to applicable Florida Statutes.

No bid will be accepted from, nor will any contract be awarded to any person or firm which is in arrears to the City upon any debt or contract or which is a defaulter as surety or otherwise upon any obligation to the City or who has failed to perform faithfully any previous contract with the City.

1.10 BID OPENING:

Bids shall be opened and publicly read in the Council Chamber, 1515 N W 167th Street; Bldg. 5 Suite 200, Miami Gardens, Florida 33169 on the date and at the time specified on the Bid Form. All Bids received after that time shall be returned, unopened.

1.11 INSPECTION, ACCEPTANCE & TITLE:

Inspection and acceptance will be destination unless otherwise provided. Title to/or risk of loss or damage to all items shall be the responsibility of the successful bidder until acceptance by the City unless loss or damage result from negligence by the City. If the materials or services supplied to the City are found to be defective or not conform to specifications, the City reserves the right to cancel the order upon written notice to the seller and return product at bidder's expense.

1.12 PAYMENT:

Payment will be made by the City after the items awarded to a bidder have been received, inspected, and found to comply with award specifications, free of damage or defect and properly invoiced.

1.13 DISPUTES:

Any actual or prospective Bidder, Proposer, Offeror or Contractor who is aggrieved in connection with a solicitation or award of a Bid or Contract may avail themselves of the procedures contained in Ordinance 2007-25-131 in order to resolve disputed matters or complaints.

The Procurement Manager shall post a tabulation of the Bid results with intended award recommendations. Posting shall be in the front office of City Hall or on the City's web site for public viewing.

Any actual or prospective bidder, proposer, offeror, or contractor who is aggrieved in connection with the solicitation or award of contract may file a written protest with the City Clerk and mailed by the protester to all responders to the bid proposal within seventy-two hours (72) hours of the City's recommendation for award or the City's actual award whichever

comes first. The written protest shall state all the particular grounds on which it is based, shall include all pertinent documents and evidence. The protest letter to the City Clerk shall include proof of mailing/receipt to other responders to the bid and shall be accompanied by a cashier's check in the amount of \$500.00 representing the filing fee, plus a cost bond in the amount of \$2,500.00 to reimburse the City for all administrative costs associated with the appeal process. The \$2,500.00 bond shall be returned to the Protester if the Protester prevails in the hearing before the hearing examiner/special master. If the Protester does not prevail the City shall keep the bond. Any grounds not stated shall be deemed waived.

Failure to file a timely formal written protest within the time period specified shall constitute a waiver by the vendor of all rights of protest under this Bid/Proposal Protest Procedure.

In the event of a timely protest, the City Manager shall select a hearing examiner or special master, who shall be a member of the Florida Bar, who shall hold a hearing and submit written findings and recommendations within fifteen (15) days of the filing of the protest. The hearing examiner shall consider the written protests, supporting documents in evidence, the City's recommendations and supporting documentation and all evidence presented at the hearing. Such finding and recommendation shall be filed with the City Clerk.

The hearing examiner's findings and recommendations shall be final. Appeals of a decision by the hearing examiner shall be to the Miami-Dade County Circuit Court. The prevailing party in the appeal may be entitled to recover any and all attorneys' fees and costs incurred in the appeal.

1.14 LEGAL REQUIREMENTS:

Federal, State, county and City laws, ordinances, rules and regulations that in any manner affect the items covered herein apply. Lack of knowledge by the bidder will in no way be a cause for relief from responsibility.

The individual executing this proposal on behalf of the Company warrant to the City that the Company is a Florida corporation duly constituted and authorized to do business in the State of Florida, is in good standing and that Company possesses all of the required licenses and certificates of competency required by the State of Florida and the County of Miami-Dade to perform the work herein described.

1.15 INDEMNIFICATION:

To the fullest extent permitted by Laws and Regulations, Contractor shall indemnify and hold harmless the City and their consultants, agents and employees from and against all claims, damages, losses and expenses, direct, indirect or consequential (including but not limited to fees and charges of attorneys and other professionals and court costs) arising out of or resulting from the performance of the work, provided that any such claim, damage, loss or expense (a) is attributable to bodily injury, sickness, disease or death, or to injury to or destruction of tangible property (other than the work itself) including the loss of use resulting there from and (b) is caused in whole or in part by any willful and wanton or negligent or gross negligent acts or omission of Contractor, any subcontractor, any person or organization directly or indirectly employed by any of them to perform or furnish any of the work or anyone for whose acts any of them may be liable, regardless of whether or not it is caused in part by a party indemnified hereunder or arises by or is imposed by Law and Regulations regardless of the negligence of any such party.

In any and all claims against the City or any of their consultants, agents or employees by any employee of Contractor, any Subcontractor, any person or organization directly or indirectly employed by any of them to perform or furnish any of the work or anyone for whose acts any

of them may be liable, the indemnification obligation under the above paragraph shall not be limited in any way by any limitation on the amount or type of damages, compensation or benefits payable by or for Contractor or any such Subcontractor or other person or organization under workers or workman's compensation acts, disability benefit acts or other employee benefit acts.

It is the specific intent of the parties hereto that the foregoing indemnification complies with Florida Statute 725.06 (Chapter 725). It is further the specific intent and agreement of the parties that all of the Contract Documents on this project are hereby amended to include the foregoing indemnification and the "Specific Consideration" therefore.

The official title of the City is "City of Miami Gardens". This official title shall be used in all insurance, or other legal documentation. City of Miami Gardens is to be included as "Additional Insured" with respect to liability arising out of operations performed for City of Miami Gardens by or on behalf of Contractor or acts or omissions of Contractor in connection with such operation.

1.16 PATENTS & ROYALTIES:

The bidder, without exception, shall indemnify and save harmless the City of Miami Gardens, Florida and its employees from liability of any nature or kind, including cost and expenses for, or on account of, any copyrighted, patented, or unpatented invention, process, or article manufactured or used in the performance of the contract, including its use by The City of Miami Gardens, Florida. If the bidder uses any design, device or materials covered by letters, patent, or copyright, it is mutually understood and agreed, without exception, that the Bid prices shall include all royalties or cost arising from the use of such design, device, or materials in any way involved in the work.

1.17 OSHA:

The bidder warrants that the product and services supplied to the City of Miami Gardens, Florida shall conform in all respects to the standards set forth in the Occupational Safety and Health Act of 1970, as amended, and the failure to comply with this condition will be considered as a breach of contract. Any fines levied because of inadequacies to comply with these requirements shall be borne solely by the bidder responsible for same.

1.17A SAFETY PRECAUTIONS:

The bidder shall, if required, maintain suitable and sufficient guards and barriers and, at night, suitable and sufficient lighting for the prevention of accidents and all minimum safety standards required by Municipal, County, State and Federal ordinances and laws shall be strictly met by the bidder

1.18 SPECIAL CONDITIONS:

Any and all Special Conditions that may vary from these General Conditions shall have precedence.

1.19 ANTI-DISCRIMINATION:

The bidder certifies compliance with the non-discrimination clause contained in Section 202, Executive Order 11246, as amended by Executive Order 11375, relative to equal employment opportunity for all persons without regard to race, color, religion, sex or national origin.

1.20 QUALITY:

All materials used for the manufacture or construction of any supplies, materials or equipment covered by this Bid shall be new. The items Bid must be new, unless recycled materials are certified by bidder, the latest model, of the best quality, and highest grade workmanship.

1.21 LIABILITY, INSURANCE, LICENSES AND PERMITS:

Where bidders are required to enter or go onto City of Miami Gardens property to deliver materials or perform work or services as a result of a Bid award, the successful bidder will assume the full duty, obligation and expense of obtaining all necessary licenses, permits and insurance and assure all work complies with all Miami-Dade County and City of Miami Gardens building requirements and the Florida Building Code. The bidder shall be liable for any damages or loss to the City occasioned by willful, wanton or gross negligence of the bidder (or agent) or any person the bidder has designated in the completion of the contract as a result of the Bid.

1.22 BID BONDS, PERFORMANCE BONDS, CERTIFICATES OF INSURANCE:

Bid Bonds, when required, shall be submitted with the Bid in the amount specified in Special Conditions. After acceptance of Bid, the City will notify the successful bidder to submit a performance bond and certificate of insurance in the amount specified in Special Conditions.

1.23 DEFAULT/FAILURE TO PERFORM:

The City shall be the sole judge of nonperformance, which shall include any failure on the part of the successful bidder to accept the award, to furnish required documents, and/or to fulfill any portion of this contract within the time stipulated.

Upon default by the successful bidder to meet any terms of this agreement, the City will notify the bidder three (3) days (weekends and holidays excluded) to remedy the default. Failure on the contractor's part to correct the default within the required three (3) days shall result in the contract being terminated and upon the City notifying in writing the contractor of its intentions and the effective date of the termination. The following shall constitute default:

- A) Failure to perform the work required under the contract and/or within the time required or failing to use the subcontractors, entities and personnel as identified and set forth, and to the degree specified in the contract.
- B) Failure to begin the work under this contract within the time specified.
- C) Failure to perform the work with sufficient workers and equipment or with sufficient materials to ensure timely completion.
- D) Neglecting or refusing to remove materials or perform new work where prior work has been rejected as non conforming with the terms of the contract.
- E) Becoming insolvent, being declared bankrupt, or committing act of bankruptcy or insolvency, or making an assignment renders the successful bidder incapable of performing the work in accordance with and as required by the contract.
- F) Failure to comply with any of the terms of the contract in any material respect.

In the event of default of a contract, the successful bidder shall pay all attorney's fees and court costs incurred in collecting any damages. The successful bidder shall pay the City for any and all costs incurred in ensuing the completion of the project.

1.24 CANCELLATION:

The City of Miami Gardens reserves the right to cancel this contract by written notice to the contractor effective the date specified in the notice should any of the following apply:

- A) The contractor is determined by the City to be in breach of any of the terms and conditions of the contract and/or to have failed to perform his/her services in a manner satisfactory to the City. In the event the contractor is found to be in default, the contractor will be paid for

all labor and materials provided as of the termination date. No consideration will be given for anticipated loss of revenue or the canceled portions of the contract.

- B) The City has determined that such cancellation will be in the best interest of the City to cancel the contract for its own convenience.
- C) Funds are not available to cover the cost of the services. The City's obligation is contingent upon the availability of appropriate funds.

1.25 BILLING INSTRUCTIONS:

Invoices, unless otherwise indicated, must show purchase order numbers; work order number and/or quotation number, if applicable; details of service(s) performed including service date, brief description, and shall be submitted in DUPLICATE to Accounts Payable, City of Miami Gardens, 1515 N W 167th Street; Bldg. 5 Suite 200, Miami Gardens, Florida 33169.

1.26 SUBSTITUTIONS:

The City of Miami Gardens, Florida WILL NOT accept substitute shipments of any kind. Bidder(s) is expected to furnish the brand quoted in their Bid once awarded. Any substitute shipments will be returned at the bidder's expense.

1.27 FACILITIES:

The City reserves the right to inspect the bidder's facilities at any time with prior notice.

1.28 BID TABULATIONS:

Bidders desiring a copy of the Bid tabulation may request same by enclosing a self-addressed stamped envelope with the Bid.

1.29 APPLICABLE LAW AND VENUE:

The law of the State of Florida shall govern the contract between the City of Miami Gardens and the successful bidder and any action shall be brought in Miami-Dade County, Florida. In the event of litigation to settle issues arising hereunder, the prevailing party in such litigation shall be entitled to recover against the other party its costs and expenses, including reasonable attorney fees, which shall include any fees and costs attributable to appellate proceedings arising on and of such litigation.

1.30 CLARIFICATION AND ADDENDA TO BID SPECIFICATIONS:

If any person contemplating submitting a Bid under this Invitation for Bid is in doubt as to the true meaning of the specifications or other Bid documents or any part thereof, the Bidder must submit to the City of Miami Gardens Procurement Manager at least seven (7) calendar days prior to scheduled Bid opening, a request for clarification. All such requests for clarification must be made in writing and the person submitting the request will be responsible for its timely delivery.

Any interpretation of the Bid, if made, will be made only by Addendum duly issued by the City of Miami Gardens Procurement Manager. The City shall issue an Informational Addendum if clarification or minimal changes are required. The City shall issue a Formal Addendum if substantial changes which impact the technical submission of Bids is required. A copy of such Addendum will be sent to each Bidder receiving the Invitation for Bid. In the event of conflict with the original Contract Documents, Addendum shall govern all other Contract Documents to the extent specified. Subsequent addendum shall govern over prior addendum only to the extent specified.

1.31 CONTRACT:

A) A contract may be awarded to the lowest responsive, responsible Bidder(s) whose Bid(s), conforming to the Invitation for Bid, is most advantageous to the City of Miami Gardens. The lowest responsive, responsible Bidder(s) will be determined in conjunction with the method of award which is described in the Special Conditions. Tie Bids will be decided as described herein.

B) The City shall award a contract to a Bidder through action taken by the City Council or the City Manager of the City of Miami Gardens, Florida.

C) The General Terms and Conditions, the Special Conditions, the Technical Specification, and the Bidder's Bid are collectively and integral part of the contract between the City of Miami Gardens and the successful Bidder.

D) While the City of Miami Gardens may determine to award a contract to a Bidder(s) under this Invitation to Bid, said award may be conditional on the subsequent submission of other documents as specified in the Special Conditions. The Bidder shall be in default of any conditional award if any of these documents are not submitted in a timely manner and in the form required by the City. If the Bidder is in default, the City, through the Procurement Manager, will void its acceptance of the Bidder's offer and may determine to select the second lowest responsive, responsible Bidder or re-solicit Bids. The City may, at its sole option, seek monetary restitution from the defaulting Bidder as a result of damages or excess costs sustained and/or may prohibit the Bidder from submitting future Bids for a period of one year.

E) The City reserves the right to exercise the option to renew a term contract of any successful Bidder(s) to a subsequent optional period; provided that such option is stipulated in the Special Conditions and is contained in any contract ultimately awarded in regard to this Bid.

F) The City reserves the right to automatically extend any contract for a maximum period not to exceed ninety (90) calendar days in order to provide City departments with continual service and supplies while a new contract is being solicited, evaluated and/or awarded, in regard to this Bid.

G) The Bidder agrees and understands that the contract may not be construed as an exclusive arrangement and further agrees that the City may, at any time, secure similar or identical services at its sole option.

1.32 ASSIGNMENT:

The contractor shall not assign, transfer, convey, sublet or otherwise dispose of any contract, including any or all of its right, title, or interest therein, or his or its power to execute such contract to any person, company or corporation without prior written consent of the City of Miami Gardens, which consent may be withheld.

1.33 LAWS, PERMITS AND REGULATIONS:

The bidder shall obtain and pay for all licenses, permits and inspection fees required for this project; and shall comply with all laws, ordinances, regulation building code requirements applicable to the work contemplated herein.

1.34 OPTIONAL CONTRACT USAGE:

Other State agencies, and/or Governmental Entities in the State of Florida may purchase from the resulting contract. Contractors shall sell these commodities or services to the other State agencies and/or Governmental Entities in the State of Florida at the agencies' and/or entities option or as otherwise provided by law.

1.35 SPOT MARKET PURCHASES:

It is the intent of the City to purchase the items specifically listed in this Bid from the selected bidder. However, items that are to be "Spot Market Purchased" may be purchased by other methods, i.e. Federal, State or local contracts.

1.36 WARRANTIES OF USAGE:

Any estimated quantities listed are for information and tabulation purposes only. No warranty or guarantee of quantities needed is given or implied. It is understood that the Contractor will furnish the City's needs as they arise.

1.37 PUBLIC ENTITY CRIMES:

As provided in Section 287.133(2) (a), Florida Statutes, a person or affiliate who has been placed on the convicted vendor list following a conviction for a public entity crime may not submit a Bid on a contract to provide any goods or services to a public entity, may not submit a Bid on a contract with a public entity for the construction or repair of a public building or public work, may not submit Bids on leases of real property to a public entity, may not be awarded or perform work as a contractor, supplier, subcontractor or consultant under a contract with any public entity, and may not transact business with any public entity in excess of the threshold amount provided S.S. 287.017 for CATEGORY TWO for a period of 36 months from the date of being placed on the convicted vendor list.

1.38 CODE OF ETHICS:

As provided in Article 9 Ethics in Public Contracting of the City of Miami Gardens Ordinance No. 2005-10-28 and Ordinance 2008-03-139 "Cone of Silence", from the time of advertising until the City Council deliberates on the making of an award, there is a prohibition on communication with the City Manager and his staff and Mayor and City Council. The ordinance does not apply to oral communications at pre-bid/proposal conference, oral presentations before selection committees, contract negotiations, public presentations made to the City Council during any duly noticed public meeting or communications in writing at any time with any City employee, official or member of the City Council unless specifically prohibited by the applicable RFP, RFQ or bid documents. A copy of all written communications must be filed with the City Clerk.

1.39 NON-COLLUSION:

By submitting this bid, Bidder certifies that this offer is made without prior understanding, agreement, or connection with any corporation, firm or person submitting an offer for the same materials, services, supplies, or equipment and is in all respects fair and without collusion or fraud.

No premiums, rebates or gratuities are permitted, either with, prior to or after any delivery of material or provision of services. Any violation of this provision may result in the Contract cancellation, return of materials or discontinuation of services and the possible removal from the vendor bid list(s).

1.40 PROHIBITION OF INTEREST:

No contract will be awarded to a bidding firm who has City elected officials, officers or employees affiliated with it, unless the bidding firm has fully complied with current Florida State Statutes and City Charter relating to this issue. Bidders must disclose any such affiliation. Failure to disclose any such affiliation will result in disqualification of the bidder and may result in removal from the vendor bid list(s).

1.41 FLORIDA PUBLIC RECORDS ACT:

All material submitted regarding this bid becomes the property of the City. Bids may be reviewed by any person ten (10) days after the public opening. Bidders should take special note of this as it relates to any proprietary information that might be included in their offer.

Any resulting contract may be reviewed by any person after the contract has been executed by the City. The City has the right to use any or all information/material submitted in response to this bid and/or any resulting contract from same. Disqualification of a bidder does not eliminate this right.

1.42 UNBALANCED BIDS:

When a unit price bid has variable or estimated quantities, and the bid shows evidence of unbalanced bid pricing, such bid may be rejected

1.43 TIED BIDS:

In the event of an identical tied bid or proposal, preference will be given to local vendors. If none of the vendors are local, preference will be given to a vendor with a Drug-Free Workplace Program in accordance with Section 287.087, Florida Statutes.

1.44 LOCAL PREFERENCE: N/A

1.45 PREFERENCE MONETARY CONTRIBUTIONS TO LOCAL SCHOOLS: N/A

1.46 DRUG FREE WORKPLACE AFFIDAVIT:

Pursuant to Section 893.02(4), Florida Statutes, each bidder shall complete the form on Drug Free Workplace Affidavit and submit same with any bid response.

1.47 SMALL, MINORITY, AND WOMEN'S BUSINESSES:

The City of Miami Gardens encourages Small, Minority, and Women's Businesses to participate in this solicitation.

The City of Miami Gardens encourages prime contractor, if subcontractors are to be let, when economically feasible, to take affirmative steps to assure that Small, Minority, and Women's Businesses are used when possible. Affirmative steps shall include:

- Placing qualified small, minority, women's and disadvantage businesses on solicitation lists;
- Assuring that small, minority, women's and disadvantage businesses are solicited whenever they are potential sources;
- Dividing total requirements, when economically feasible, into smaller tasks or quantities to permit maximum participation by small, minority, women's and disadvantage businesses;
- Establishing delivery schedules, where the requirement permits, which encourage participation small, minority, and women's businesses;
- Using the services and assistance of the Small Business Administration, and the Minority Business Development Agency of the Department of Commerce.

SIDEWALK REPLACEMENT & INSTALLATION – ANNUAL CONTRACT

ITB#09-10-069

August 5, 2010

2.0 SPECIAL CONDITIONS

2.1 PURPOSE:

The City of Miami Gardens, acting as lead City for the Southeast Florida Governmental Purchasing Co-operative Group, is actively seeking sealed bids from qualified contractors for the replacement and installation of new sidewalks on an as needed basis to the City and the Co-Op in full accordance with the specifications, terms and conditions herewith from a source(s) that will give prompt and efficient service.

2.2 TERM OF CONTRACT:

It is requested that the bidder quote fixed prices that will be guaranteed to the City of Miami Gardens and the Southeast Florida Governmental Co-Op for an initial period of one year which is expected to begin on or about September 1, 2010. The City reserves the right to exercise the option to renew annually (subject to the appropriation of funds), not to exceed a maximum of two (2) years. Annual renewals will be based on the successful bidder agreeing to the same terms and conditions and by filing written notice to the City not less than ninety (90) days prior to renewal date of any adjustment in the contract amount. Continuation of the contract beyond the initial period is a City prerogative; not a right of the bidder. This prerogative will be exercised only when such continuation is clearly in the best interest of the City. This contract is not an exclusive contract.

No price increase will be accepted during the initial contract period. Renewal terms allow for a request for an increase at the time of renewal based on contractor's cost increase not to exceed the current C.P.I. index at time of renewal. A written notice sent to the City for approval of any increase prior to renewal accompanied by contractor's documentation to substantiate need for price increase. No more than one price increase will be accepted during the renewal period.

The contractor may make application for price adjustment to the renewal contract if the Consumer Price Index; U.S. Bureau of Labor Statistics; All Urban Consumers; U.S. City Average; that occurred between the newest C.P.I. index publication available at time of request increases 5% or more during this period of the contract.

If during the contract period, the total C.P.I. decreases 3% or more, the contractor is required to extend to the City a price decrease equal in percentage to the percentage of the index.

Orders will be placed to vendors on as-needed when needed basis to meet each City's requirements.

2.3 METHOD OF AWARD:

The City reserves the right to award to a primary and secondary contractor if it is in the best interest of the City and Co-Op. If a multiple award is given, Purchase Orders for task orders will be made on the basis of the unit prices submitted and the availability of the bidders work unit to the schedule set by the City. These items and quantities are projections, and shall not be construed as a base bid or a guaranteed amount.

2.4 PAYMENT:

Payment will be made upon final completion and acceptance, by the City, of each assigned project. Payments will be made in accordance with Florida Prompt Payment – 45 days from receipt of invoice. No draws or partial payments will be made while work is in progress.

The City will pay the contract price minus any liquidated damages and/or other damages to the Contractor upon final completion and acceptance.

Bidder must submit a lump sum price inclusive of all labor, parts/supplies, equipment needed to furnish, deliver, erect, install and connect completely all of the material and appliances described herein and in the drawings, and supply all other incidental material and appliances, tools, transportation, etc., required to make the work complete and to leave the area in first class operating condition.

INVOICES:

Invoices submitted for payment shall contain the purchase order number and/or work order/bid number; details of service(s) performed including service date, unit costs and location of service. Copies of invoices or other appropriate documentation shall be provided for each job to support their actual costs prior to reimbursement upon request from the City. Failure to itemized the aforementioned shall result in the invoice being returned for adherence to the same.

PURCHASING CARD PROGRAM:

The City has implemented a purchasing card program through Sun Trust Bank, using the VISA network. Contractors with purchasing card capability will receive payment from the VISA purchasing card in the same manner as other Visa purchases. Accordingly, respondents with present purchasing card capability shall have the ability to accept VISA or take whatever steps necessary to implement the ability before the start of the agreement term. The City can only accept VISA, however, the purchasing card is not the exclusive method of payment. Please indicate your ability to accept Visa purchasing card on Bid Form.

2.5 COMPLETION TIME:

Contractor shall actively start each project within ten (10) calendar days after written Purchase Orders/task orders (furnished by mail or facsimile) and shall stipulate final completion time in consecutive calendar days prior to start of each task order.

The Work shall be carried on regularly and uninterruptedly with sufficient force to insure its completion with the time limit set. Failure to begin shall render the Contractor liable to the City for the sum of One Hundred Dollars (\$100.00) per day as liquidated damages for each and every calendar day delay in commencing work. For reasons satisfactory to the City's Representative, the City may waive any claims on the Contractor for the damages referred to.

The City seeks a source of supply that will provide accurate and timely completion. The awarded contractor must adhere to completion schedules. If, in the opinion of the Public Works Director, the successful contractor fails at any time to meet the requirements herein, including completion requirements, then the contract may be cancelled upon written notification for default of contract.

2.6 FAILURE TO PERFORM:

If, in the opinion of the City's representative, the Contractor refuses to begin work, improperly perform said work, or shall neglect or refuse to take out or rebuild such work, as shall have been rejected or as being defective or unsuitable, then City's representative may notify the Contractor to repair and replace work immediately or discontinue all work under this Contract.

If at any time the City's representative shall be of the opinion that the said work is being unnecessarily delayed and will not be finished within the prescribed time then City's representative may notify the Contractor to discontinue all work under this Contract. The Contractor shall immediately respect said notice and stop said work and cease to have any rights in the possession of the ground and shall forfeit this contract.

The City may thereupon look to the next lowest and responsive and responsible contractor to complete the work or advertise for bids and let a contract for the uncompleted work in the same manner as was followed in the letting of this Contract and charge the cost thereof to the original Contractor upon his contract. **Any excess cost arising therefrom over and above the original contract price shall be charged to the Contractor.**

2.7 PRICES SHALL BE FIXED AND FIRM FOR TERM OF CONTRACT:

If the bidder is awarded a contract under this proposal solicitation, the prices quoted by the bidder on the Bid Form shall remain fixed and firm during the term of contract; provided, however, that the bidder may offer incentive discounts from the fixed price to the City at any time during the contractual term.

2.8 INSURANCE:

Bidders must submit with their proposal, proof of insurance meeting or exceeding the following requirements or a letter of intent to provide the following requirements if awarded the contract:

- 2.8.1 Worker's Compensation Insurance – as required by law
The City of Miami Gardens will not accept filed certificates of exemption forms for Worker's Compensation Insurance.
- 2.8.2 Employer's Liability Insurance - \$1,000,000 per occurrence
- 2.8.3 General Liability Insurance - \$1,000,000 per person and \$1,000,000 per accident for bodily injury
- 2.8.4 Automobile Liability Insurance - \$500,000 per occurrence, \$500,000 per accident for bodily injury and \$500,000 per accident for property damage

The required insurance coverage shall be issued by an insurance company authorized and licensed to do business in the State of Florida, with the minimum rating of B+ or better, in accordance with the latest edition of A.M. Best's Insurance Guide.

The successful bidder must submit, no later than ten (10) days after award and prior to commencement of any work, a Certificate of Insurance naming the City as additional insured.

Contractor shall require all of its subcontractors to provide the aforementioned coverage as well as any other coverage that the contractor may consider necessary, and any deficiency in the coverage or policy limits of said subcontractors will be the sole responsibility of the contractor.

2.9 CONTACT PERSON:

For any additional information regarding the specifications and requirements of this proposal, contact: Procurement Department, Facsimile: (305) 474-1285, e-mail: pthompson@miamigardens-fl.gov.

2.10 PERFORMANCE BOND:

The successful contractor(s) will be required to furnish a Performance Bond and Payment Bond for 100% of the total task order if it exceeds \$150,000, to be in the form of a Cashier's

Check, made payable to the City; a bond written by a surety company authorized to do business in the State of Florida and shall comply with State Statute 287.0935; or an Irrevocable Letter of Credit. If the latter is chosen, it must be written on a bank located Miami-Dade, Broward or Palm Beach County, be in the amount of the total task order and should clearly and expressly state that it cannot be revoked until express written approval has been given by the City. The City, to draw on same, would merely have to give written notice to the bank with a copy to the successful contractor(s).

2.11 LIQUIDATED DAMAGES:

Purchase Orders will be issued and completion times will be mutually agreed upon between the contractor and the City. Liquidated damages of \$100.00 per calendar day will be deducted from the contract sum for each and every calendar day delay in commencing work or elapsing beyond the specified time for completion for each Purchase Order.

2.12 BID CLARIFICATION:

Any questions or clarifications concerning this Proposal shall be submitted in writing by mail or facsimile to the Procurement Department, 1515 NW 167th Street; Bldg. 5 Suite 200, Miami Gardens, Florida 33169, FAX: (305) 474-1285, e-mail: wgarviso@miamigardens-fl.gov The proposal title/number shall be referenced on all correspondence. All questions must be received no later than **July 22, 2010 @ 3:00 p.m.** All responses to questions/clarifications will be sent to all prospective bidders in the form of an addendum. **NO QUESTIONS WILL BE RECEIVED VERBALLY OR AFTER SAID DEADLINE.**

2.13 CONDITIONS OF WORK:

If property (public or private) is damaged performing work specified or is removed for the convenience of the work, it shall be repaired or replaced at the expense of the contractor in a manner acceptable to the City. Such property shall include but not limited to: roads, driveways (whether concrete or asphalt), approaches (whether concrete or asphalt), sod, walls, fences, water features, footings, underground utilities, shrubs, trees, etc.

Contractor shall submit to the City authorized personnel for review, pictures or video of the work site(s) having pre-existing damage to roadways, driveways, approaches, sod, swales, adjacent improvements, etc. before beginning work. Failure to do so shall obligate the contractor to make repairs per above paragraph.

Contractor shall notify the City authorized personnel of any pre-existing damage to tree trunks or limbs before beginning work. Failure to do so shall obligate the contractor for tree removal, and canopy replacement as per D.E.R.M. codes, ordinances and or resolutions.

2.14 PROTECTION:

Contractor shall be solely responsible for pedestrian and vehicular safety and control within the work site and shall provide the necessary warning devices, barricades and ground personnel needed to give safety, protection and warning to persons and vehicular traffic within the area. All safety devices must have suitable and sufficient lighting for the prevention of accidents. All minimum safety standards required by Municipal, County, State and Federal ordinances and laws shall be strictly met by the contractor.

2.15 HOURS OF WORK:

Contractor will perform work Monday through Friday from 7:30 a.m. to 4:00 p.m., excluding holidays unless prior approval is given by the City.

2.16 EMPLOYEES:

Contractor shall be responsible for the appearance of all working personnel assigned to the project (clean and appropriately dressed at all times). Personnel must be able to supply proper identification at all times.

All employees of the contractor shall be considered to be at all times the sole employees of the contractor, under the contractor's sole direction, and not an employee or agent of the City. The contractor shall supply competent and physically capable employees and the City may require the contractor to remove any employee it deems careless, incompetent, insubordinate or otherwise objectionable and whose presence on City property is not in the best interest of the City. City shall not have any duty to implement or enforce such requirements.

Contractor shall assign an "On Duty" supervisor who speaks and reads English.

2.17 PERMITS:

No permits are required for the City of Miami Gardens, however, inspections shall be made in accordance with Section 03.1602 Quality Assurance.

Contractor shall be responsible for obtaining any permits required by the other participating agencies.

Contractor shall verify all locations of underground utilities with Sunshine One Call, Peoples Gas, Southern Bell, TCI cable, etc. prior to any work.

Contractor shall contact proper authorities for raising utility boxes (manhole covers, valve boxes, water meters, sanitary sewer clean-outs).

All work not stated herein shall be in compliance with the Florida Building Code and all other national, state, and local codes and regulations. All permits to be posted on job site.

All inspections shall be requested a minimum of twenty-four (24) hours prior to inspection. Inspection shall be required at the following stages of construction:

- a. Subgrade prep completion
- b. Sidewalk formed prior to pouring concrete
- c. Paving
- d. Final

2.18 WARRANTY:

The successful contractor will be required to warranty all materials and workmanship to be in compliance with the specifications for a period of six months after acceptance of project.

2.19 REFERENCES:

Each bid must be accompanied by a list of five (5) references, of prior experience and similar work, which shall include company/municipal entity, contact person, e-mail address, telephone number and facsimile number. Local references are preferred, as the City reserves the right to visit each reference submitted. It is the responsibility of the bidder to ascertain that the contact person will be responsive.

STATEMENT OF EXPERIENCE OF BIDDER form must be completed and returned with Bid Form.

2.20 BID SUBMITTAL:

All bids submitted shall include the completed Bid Form and all required product information and any other items as indicated on the Bid Form. Bids will be considered "Non-Responsive" if the required information is not submitted by the date and time specified.

Before submitting bid package, each bidder shall make all investigations and examinations necessary to ascertain if any addendums were issued by the Procurement Department.

2.21 LATE BIDS:

The City of Miami Gardens cannot be responsible for bids received after opening time and encourages early submittal.

2.22 EXCEPTIONS TO SPECIFICATIONS:

Exceptions to the specifications shall be listed on the Bid Form and shall reference the section. Any exceptions to the General or Special Conditions shall be cause for the proposal to be considered non-responsive.

2.23 COMPLETE INFORMATION REQUIRED ON BID FORM:

All bids must be submitted on the attached Bid Form and all blanks filled in. To be considered a valid proposal, the ORIGINAL AND THREE COPIES of the Invitation to Bid and Bid Form pages must be returned, properly completed, in a sealed envelope as outlined in the first paragraph of General Conditions.

STATEMENT OF BIDDER'S EXPERIENCE

PROOF OF INSURANCE

REFERENCES

CONTRACTOR QUESTIONNAIRE

SUB-CONTRACT LIST

2.24 PARTICIPATING AGENCIES

Each participating governmental City will be responsible for issuing its own Purchase Obligations/task orders. Each City will require separate billings, be responsible for payment to the awarded contractor and issue its own tax exemption certificates as required by contractor. Invoicing instructions, site locations, and bonding requirements, if applicable, will be in accordance with the respective City's requirements.

Any reference in this document to a single City, will be understood as referring to all participating agencies referenced in this bid.

Municipalities and other governmental agencies which are not members of the Southeast Florida Governmental Cooperative Purchasing Group are strictly prohibited from utilizing any contract or purchase order resulting from this bid award. However, other Co-Op members may participate in this contract for new usage, during the contract term, or on any contract extension term, if approved by the lead City. New Co-Op members may participate in any contract, on acceptance and approval by the lead City.

Name & Address	Contact	Phone
City of Deerfield Beach 210 SW Goolsby Blvd. Deerfield Beach, FL 33442	Donna Council	954-480-4380
City of Miami Gardens 1515 NW 167 th Street #200 Miami Gardens, FL 33169	Pam Thompson	305-622-8000
City of Lauderdale Lakes	Vincent Mullen	954-535-2793

4300 NW 37 th Street Lauderdale Lakes, FL 33319		
City of Coconut Creek 4800 West Copans Road Coconut Creek, FL 33063	David Santucci	954-956-1584
City of Sunrise 1601 NW 136 th Avenue Suite 101 Sunrise, FL 33323	Mark Winslow Wendy Lorenzo	954-572-2390 954-572-2485
City of Oakland Park 3650 NE 12 th Avenue Oakland Park, FL 33334	Art Saey	954-630-4433
City of Dania Beach 100 W. Dania Beach Blvd. Dania Beach, FL 33004	Leo Williams	954-924-3743
Town of Pembroke Park	Jeanne Peterson	954-966-4600 ext. 238

SIDEWALK REPLACEMENT & INSTALLATION – ANNUAL CONTRACT

ITB#09-10-069
August 5, 2010

3.0 TECHNICAL SPECIFICATIONS

GENERAL SCOPE OF WORK – Contractor will not be required to replace or install less than a combined 100 linear feet of sidewalks within one square mile per task order and/or purchase order.

- A. Contractor shall furnish all materials, labor, supervision, and transportation, permits, licenses, equipment and any incidentals necessary to perform these services as stated herein.
- B. The work includes removal of grass and other materials to prepare the ground for sidewalk installation. Additional tasks will include installation of handicap ramps at intersections of Streets and Avenues where indicated by each City. All form work and site preparation shall be conducted with minimum impact and/or damage to the adjacent properties.
- C. Remove and dispose of existing trees as indicated by each City. All trees to remain shall be preserved. See Tree Removal and Preservation Specifications. Size of tree will be paid based on proof from the contractor of size. If proof is not provided, each City will make such determination of size deemed acceptable.
- D. New four and/or six inches thick sidewalks shall be constructed in accordance with Florida Accessibility Code for Building Construction, latest edition, and Section 522 of the FDOT-SSR&BC, latest edition and other requirement as required.
- E. Handicap ramps shall be installed at intersections of Streets and Avenues within the ROW only, per Typical Handicap Ramp Layout Detail.
- F. Any disturbed swale areas, private property, other public property shall be re-sodded per Sod Specifications and graded properly as per specifications at the Contractor's expense.
- G. Where any existing elevation is lower than sidewalk, lime rock must be spread and compacted to a minimum of 95%. Lime rock may be used where there is no approach and between new sidewalk to fill any gaps. Compacted to avoid settling. Delivery Ticket must be provided to City to determine payment. City Engineer must pre-approve.
- H. Any damage to the roadway, driveway approaches, driveways, abutting sidewalks, aprons surrounding catch basins, manholes, etc. shall be repaired at no expense to the City, if determined by the City to be repairs due to negligence or lack of coordination on the part of the Contractor. Re-paving shall be per Pavement Specifications and Miami-Dade County Public Works Manual.
- I. Purchase and installation of Florida #1 Live Oak Trees, Mahogany, Crape Myrtle and or Silver Buttonwood with 10' to 12' overall height.
- J. Drawings added include the following:
 - 1. Planting Detail
 - 2. FDOT Curb and Gutter Drawing
 - 3. Pedestrian Ramps
 - 4. Sidewalk Detail

- K. At the discretion and direction of each City, each block where sidewalks are to be installed, surveys will be required to establish R.O.W. centerline and width and/or to establish the required property line for the construction of new sidewalks. This service shall be performed by a Professional Registered Surveyor in the State of Florida.

END OF SECTION

REPLACEMENT & INSTALLATION OF SIDEWALKS
SECTION 031500
TEMPORARY FACILITIES

03.151 SECURITY

- A. The contractor is responsible for project security. Contractor shall protect and secure the site, materials, and equipment from theft and damage, by whatever means deems effective, at Contractor's cost.
- B. Work site(s) must be protected properly in accordance with all Federal, State, County and Municipal laws and ordinances, at the end of each work day and weekends.

03.152 SPECIAL CONTROLS

- A. Water Control:
1. Keep excavations dry.
 2. Shape excavations, particularly piles of excavated material, so as to divert water from excavations and low spots.
- B. Erosion and Sedimentation Control:
1. Prevent the pollution of land, air and water and control the erosion, washout and surface runoff of earth and stockpiled materials.
 2. Fill material shall contain no organic matter other than the normal organic component of topsoil.
 3. Immediately upon completion of final grading, stabilize graded areas with temporary or permanent vegetation, mulch, or paving.

03.153 MAINTENANCE OF TRAFFIC

- A. Control of vehicles and Persons:
1. Provide trained personnel to assure the orderly flow of vehicular traffic during construction.
 2. Contractor shall submit a Maintenance of Traffic Plan (MOT) for review and acceptance by each City when required.
 3. Upon completion of work each day the lanes shall be opened to traffic. Lane closure procedures shall be in accordance to the F.D.O.T. Standards provided.
 4. Ensure that private property driveways are usable upon completion of daily work.
- B. Limit of Operations:
1. Any damage or alterations to area outside limit of operations shall be returned to original condition within 24 hours at no cost to the City.

03.154 PROJECT IDENTIFICATION

- A. No signs, or advertisements will be allowed to be displayed on the premises without the approval of each City's Representative.

03.155 PROJECT HOUSEKEEPING

- A. Trash Disposal
 - 1. Keep adjacent streets and site free from accumulations of waste materials and rubbish.
 - 2. Provide central waste area with containers for at least daily removal.
- B. Burning:
 - 1. Do not burn any trash or other material on site.
- C. Material Removal/Additional Soil:
 - 1. Excess material, including demolished material, roots from trees, excess earth and excess building materials are property of the contractor and shall be removed from site daily and legally disposed of.
 - 2. All material excavated or brought to the project for use/reuse shall be piled within the Public Right-of-Way in a location previously approved by the City.
 - 3. The Contractor shall leave all locations in an acceptable manner once concrete has been poured. Contractor shall coordinate work to ensure that all sites are clean, sodded as required, and acceptable prior to mobilizing to other locations.
 - 4. The Contractor shall replace any sod, concrete and/or asphalt removed, damaged or displaced during demolition or performance of work at Contractor expense.

END OF SECTION
031500

REPLACEMENT & INSTALLATION OF SIDEWALKS
SECTION 031600
POURED CONCRETE

Sidewalks & Handicap Ramps & Curbs

03.1601 DESCRIPTION

- A. Provide poured concrete at locations where no sidewalks or ramps exist to be per drawings and specifications
- B. Provide poured concrete in locations where existing sidewalk must be replaced per drawings and specifications
- C. Provide curb cuts where proposed sidewalks and/or handicap ramps are installed and there is a conflict with existing curbs. Curb cuts shall be per FDOT design standards. All curbs shall be cut and transitioned in an acceptable manner. All surrounding pavement, sod, asphalt shall be restored to the existing elevation at the Contractor's expense.

03.1602 QUALITY ASSURANCE

- A. Testing and Inspection of Installation
 - 1. Concrete shall not be poured, placed or installed until such time an inspection of all sites has taken place by the City authorized personnel. Inspections shall be made to verify appropriate compaction of subbase and to check forms for line and grade.

2. The City will inspect the installation. If any concrete is found to be installed improperly, the Contractor will be required to remove and replace promptly. Upon notifications from the contractor, the City will perform a re-inspection. Should additional concrete be found to be unsatisfactorily installed, and additional inspections required, these inspections shall be at the Contractor's cost, at the discretion of the City.

03.1603 PRODUCTS

- A. Concrete
 1. Forms:
Steel, wood, or other suitable material of size and strength to resist movement during concrete placement. Conform to ACI 301.
 2. All Joints if required by City:
Joints must be scribed to help prevent cracking per FDOT design standards
 3. Concrete Mix Design:
Mix concrete shall be provided from a FDOT approved supplier. Mix design certification will be required before the unset of any work

Design Mix to produce normal-weight concrete consisting of Portland cement, aggregate and water to produce the following properties:
 - a. Compressive strength: 3000 psi, minimum at 28 days
 - b. Slump range: 4" to 6"
 - c. Un-reinforced
- B. Biobarrier
 1. Hort Enterprises – Ft. Lauderdale (954) 771-5761 or equal. Twelve inch (12") wide roll.
- C. Lime Rock – Miami Oolite Formation
 1. Lime rock shall be in accordance with FDOT Standard Specifications for Road and Bridge Construction, Section #911 or latest edition. Material shall be fragmented or broken up to such a size that not less than 97% will pass a 3 1/3" sieve.
 - a. Carbonates of Calcium and Magnesium Min. 60.0
OR LBR exceed 150
 - b. Organic Matter Max. 0.5
- D. Detectable Warning Surfaces
 1. Cast-In-Place type shall be in accordance with ADA Regulation for Detectable Warning on Curb Ramps and shall consist of a surface of truncated domes aligned in a square of radial grid pattern and shall comply with R304.
 2. Replaceable or Surface Mount type shall be in accordance with ADA Regulation for Detectable Warning on Curb Ramps and shall consist of a surface of truncated domes aligned in a square of radial grid pattern and shall comply with R304.

03.1604 EXECUTION

- A. Inspect surfaces for conditions that will adversely affect the quality of installation. Do not proceed with the installation until adverse conditions have been corrected.
- B. Compact subbase surface immediately before placing concrete.
- C. Clearing and grubbing, removal and disposal of existing dirt, grass, roots.

- D. Replace organic material with clean fill and installed up to 6" lifts and compact to a minimum of 95% compaction. Contractor shall submit type of clean fill for City's approval prior to construction.
- E. The City has the right to request compaction test at locations chosen by the City. Should compaction tests be found to be unsatisfactory, and additional inspections required, these inspections shall be at the Contractor's cost, at the discretion of the City.
- F. Concrete finishing:
 - a. Smooth surface by screeding and floating. Produce a uniform texture.
 - b. Work edges of slab to a ½" radius. Eliminate tool marks on concrete surface.
 - c. Broom finish after excess moisture has disappeared.

03.1605 INSTALLATION

- A. General: Comply with requirements Florida Accessibility Code for Building Construction, latest edition, and Section 522 of the FDOT-SSR&BC, latest edition and other requirement as required.
- B. All sidewalks and ramps shall be four inches (4") or six inches (6") thick except across driveways, driveway approaches, and first five feet (5') of ramps closest to paved roadways where that shall be six inches (6") thick.
- C. Sidewalk elevation shall be two inches (2") above the crown of the road, at the back side of the sidewalk, and the pitch shall be ¼ inch per foot toward the road. Elevation may be adjusted, based on the existing grade, as approved by the City.
- D. Contractor shall ensure that where handicap ramps are installed per FDOT design standards. The cut shall be provided at least one foot (1') behind the transition point. All modifications to the curb shall match existing curbs and shall be flush without exception.
- E. No wire or wire mesh shall be utilized.
- F. Concrete shall not be poured, placed, or installed until such time as an inspection of all sites has taken place as per Section 3.1602 QUALITY ASSURANCE. **IF ANY WORK OR PORTION OF WORK HAS NOT BEEN INSPECTED AS PER SECTION 3.1602, THAT PORTION OF WORK SHALL BE IMMEDIATELY REMOVED AND REPLACED ONCE THE INSPECTION HAS BEEN CONFIRMED AT NO COST TO THE CITY.**
- G. Place concrete using methods which prevent segregation of mix. Consolidate concrete along face of forms and adjacent to transverse joints with internal vibrator. Keep vibrator away from joint assemblies, or side forms. Use only square-faced shovels for hand-spreading and consolidation. Consolidate with care to prevent dislocation of re-enforcing, dowel, and joint devices.
- H. Deposit and spread concrete in a continuous operation between transverse joints, as far as possible.
- I. Contractor shall replace all damaged or misaligned private walkways and driveways with a transition to the private property at 8 to 1 fill slope transition. All other locations shall have a 4 to 1 fill slope transition. Organic material or lime rock, City will determine which material, may be used in areas outside walkways and driveways that require fill slopes.

- J. Avoid premature cracking by installing expansions joint where and when required by City
- K. Utility boxes shall be raised to sidewalk elevations or flushed with sidewalk as to prevent trip hazard. If existing boxes and/or values are broken prior to installation, the City will supply replacement. If utility boxes are broken during installation Contractor must replace at its own expense.
- L. Install Biobarrier prior to forming and pouring concrete.
- M. Install Biobarrier at existing trees and new trees. Length of biobarrier shall be ten feet (10') long centered on the tree by twelve inch (12") deep at one inch – two inch (1"-2") below the top of the sidewalk. See Section 31800 for additional information.
- N. Concrete shall not be poured, installed or place around manholes, cleanouts, or other structures until they are at required elevations and alignment. Contractor shall notify the City in writing of manholes, cleanouts, or other items that may require relocation or modification prior to pour.
- O. All sidewalk that the City has determined to be replaced due to deterioration, cracking, uplifting, improper sloping, misalignments, grade, etc. will be removed and replaced as required by specification.
- P. Removal of existing sidewalk shall be performed by saw cutting the section of unacceptable sidewalk (as determined by the City) at the nearest acceptable five foot (5') flag. New sidewalk shall be poured in its place as established by specifications.
- Q. All areas where existing sidewalk is to be replaced must be prepared and graded to match adjacent sidewalk flags.
- R. All replacement sidewalk sections shall be installed to match the existing sidewalk elevation.
- S. Contractor shall restore all sites to the pre-existing condition or better, adding sod at Contractor's expense if existing is damaged. If existing site, prior to sidewalk replacement/installation, does not have sod, clean fill (soil) must be added to avoid gaps next to sidewalk.
- T. Cast-In-Place tactile units shall be used for new ramp locations. Tactile units can be pre-filled w/concrete and set in place or pressed into place in freshly poured concrete. On ramps that are perpendicular with curb line the dome pattern shall be in-line with the direction of travel. On ramps intersecting curbs on a radius, the dome pattern shall be in-line with the direction of travel to the extent practical.
- U. Replaceable or Surface Mount tactile units shall be used on existing concrete or damaged existing detectable warning surfaces. Installation area shall be cleaned of all debris, oil and grease, to ensure area is completely free of moisture. All concrete dust present on the tactile panel resulting from drilling process must be cleaned off tactile panel prior to using any caulking materials. Caulk around perimeter of entire installation using Sonneborn NP1 or approved equivalent. On ramps that are perpendicular with the curb line the dome pattern shall be in-line with the direction of travel. On ramps intersecting curbs on a radius, the dome pattern shall be in-line with the direction of travel to the extent practical.

END OF SECTION

031600

REPLACEMENT & INSTALLATION OF SIDEWALKS
SECTION 031700
PROTECTION STORM DRAINS

03.1701 PROTECTION

- A. All storm drain inlet must be protected, from sediments entering the storm water conveyance system prior to disturbance to the area.
- B. All sediment and erosion control practices must be in accordance with the Florida Department of Environmental Protection Storm Water Sediment and Erosion Control Manual Section 4.08 (Storm Drain Protection Procedures) (Best Management Practices BMPs).

END OF SECTION
031700

REPLACEMENT & INSTALLATION OF SIDEWALKS
SECTION 031800
CONCRETE CURB AND GUTTER

03.1801 DESCRIPTION

- A. All curb and gutter shall be formed and installed in accordance with State of Florida Department of Transportation Roadway and Traffic Design Standards (FDOT). Curb and gutter not installed in accordance with these specifications will be removed and replaced at the expense of the Contractor.
- B. Related work:
 - 1. Clearing and Removal: Section 031500

03.1802 QUALITY ASSURANCE

- A. Testing and Inspection of Installation
 - d. The City will inspect the installation. If any concrete is found to not be installed adequately, the Proposer will be required to remove and replace promptly. Upon notifications from the proposer, the City will perform a re-inspection. Should additional concrete be found to be unsatisfactorily installed, and additional inspections required, these inspections shall be at the Contractor's cost, at the discretion of the City.

03.1803 PRODUCTS

- A. Concrete
 - 1. Forms:

Steel, wood or other suitable material of size and strength to resist movement during concrete placement. Conform to ACI 301. Height shall be equal to the full depth of the finished sidewalk, curb and gutter with a flat top surface and be inspected and approved by the City prior to pouring.
 - 2. Concrete Mix Design:

Mix concrete in accordance with ASTM C94

Design Mix to produce normal-weight concrete consisting of Portland cement, aggregate and water to produce the following properties:

- a. Compressive strength: 3000 psi, minimum at 28 days
- b. Slump range: 4" to 6"
- c. Air content: 5% to 8%

03.1804 INSTALLATION

- A. Cast-in-place curb and gutter Type "F" shall be of thickness, size, shape and shall be 24" x 12", including drop curb, transitions, and reconstruction of base where required.
- B. Cast-in-place curb Type "D" shall be of thickness, size, shape and shall be 12" , including drop curb, transitions, and reconstruction of base where required.
- C. Valley-gutter shall be of thickness, size, shape of standard FDOT gutter
- D. Curbs shall receive a broom finish. Two 1 ½" PVC sleeves of adequate length shall be provided by the Contractor to go under all required curb and gutter to allow for electrical and water access.
- E. Gutter elevations shall maintain a consistent elevation with roadway and shall be installed so as not to obstruct the natural flow of run-off in the area.
- F. Sawcuts shall be provided every ten feet (10') to a depth of 1/8" – ¼".
- G. Proposer shall cut the roadway straight and even with asphalt cutting equipment where the curb and gutter meets the existing roadway. Any voids between the new curb and gutter and existing asphalt shall be filled with F.D.O.T. approved asphaltic concrete patch. Concrete voids shall also be filled with F.D.O.T. approved concrete patch.
- H. Clearing and grubbing, removal and proper disposal of existing curb and gutter. Restoration of sites to pre-existing condition or better, adding sod at Contractor's expense if damaged. Clean fill (soil)(if no pre-existing sod at location) must be added to avoid gaps next to curb.

END OF SECTION
031800

REPLACEMENT & INSTALLATION OF SIDEWALKS SECTION 031900 TREE REMOVAL & PRESERVATION

03.1801 REMOVALS

- A. **ONLY** the trees and/or shrubs that are deemed by the City to interfere with the intent of the contract shall be removed or root pruned as needed. All cost associated with vegetation removal and/or root pruning, trimming, clearing and grubbing, grinding of stumps and roots shall be included with the unit price.
- B. The contractor shall be required to review the site prior to performance of work and ensure no conflicts exist. Any tree in conflict with the expected location of new sidewalk shall be reported to the City for review.
- C. Remove trees and grind stumps and all surface roots to a minimum of 4" below grade.
- D. Restore the location where tree removals take place with soil and sod at grade.

03.1902 PRESERVATION

The following actions and precautions shall be done to protect any trees that will remain in all of the construction areas during construction. These trees shall be those located near new sidewalk installation.

A. Root Pruning

1. All existing trees shall be root pruned along the sidewalk prior to sidewalk removal, excavation and installation.
2. The root cutting shall be clean with no tears with root pruning machine.
3. The cut shall extend from the tree out 4 feet minimum in both directions, or as the field may permit to ensure the protection of the tree.
4. The cut shall be 12 inches below grade.
5. The cut shall be no wider than 3 inches.

B. Protective Barriers

1. Barriers shall be placed no less than 6 feet around each tree or no less than 1 foot from edge of street, sidewalk or driveway.
2. Barriers shall be a minimum of 4 feet above ground level, constructed of wood, metal or rigid plastic, in the form of a fence. No barrier shall be secured in any way to the tree.
3. Barriers shall be installed prior to construction and remain until the City authorizes their removal.
4. No excess oil, fill, equipment, building materials or debris shall be placed within the barriers.
5. The existing grade within the barrier shall not be changed.

END OF SECTION
031900

REPLACEMENT & INSTALLATION OF SIDEWALKS SECTION 032000 SOD & INSTALLATION

03.2001 MATERIALS

- A. Sod shall be St. Augustine 'Floritam', grade A.
- B. Sod shall be Bahia Sod, grade A
- C. Sod shall be weed and insect free.

03.2002 INSTALLATION

Those areas disturbed as a consequence of sidewalk installation and those areas disturbed as a consequence of Contractor mobilization and stock piling shall be restored promptly at **Contractor's expense**.

The Contractor shall not utilize methods of mobilization or execution of work that impacts private/public areas excessively and/or in a manner that is unacceptable to the City. Contractor shall ensure that all private and/or public areas impacted by the mobilization, stock piling, or lack of coordination as interpreted by the City are restored at no cost to the City.

- A. Only damaged areas of swales or private property shall be replaced. Where sidewalks require to be elevated above existing grade, swales shall be graded to a 12 to 1 fill slope with sod.
- B. Sodded areas shall have any compaction relieved, graded, clearing, grubbing, raked smooth and rocks or debris removed.
- D. Areas along street and sidewalk shall be 2 inches below that surface so installed sod will be level with that surface.
- E. Sod will be laid tightly together, and cut to a uniform edge along hard surfaces and around trees or palms. The sod around trees or palms shall be laid encircling to within 18 inches, or up to the berm surrounding newly installed trees or palms.
- G. Sod shall be watered within one hour of installation and shall be maintained moist.

03.2003 QUALITY ASSURANCE

- A. No sub-par sod, or broken pieces will be accepted, and shall be removed from the site daily.
- B. No yellow sod will be accepted.
- C. Sod shall not be pieced together with scraps that do not have sufficient roots to sustain growth.
- D. Contractor is responsible for his own square foot take-offs to provide 100% sod coverage throughout the scope of the project.
- E. Rejected areas will be removed and replaced immediately, and all sod maintained until final acceptance.

03.2004 CITY REQUESTED SOD INSTALLATION

The City may request the installation of St. Augustine or Bahia sod which shall be installed as above

END OF SECTION
032000

REPLACEMENT & INSTALLATION OF SIDEWALKS

SECTION 032100

PAVEMENT

03.210 MATERIALS

- A. Asphaltic Concrete Type III including Tack Coat
- B. Concrete 3,000 PSI

03.2101 PAVEMENT

- A. Pavement repairs of driveway approaches and section of driveways effective by installation of sidewalks shall be re-installed with one inch (1") of asphalt in accordance with the FDOT Manual of Uniform Minimum Standards for Design, Construction & Maintenance for Streets & Highways, latest edition.
- B. Concrete repairs may be limited to damage which results as part of construction and elevation changes of the new sidewalk.
- C. The City may request Contractor to repair any existing driveway approaches that are damaged prior to installation of sidewalk.

03.2102 EXECUTION

- A. Contractor shall repair asphalt/concrete driveway approaches where existing approaches are damaged by construction process **at Contractor's expense**. Contractor shall photograph all existing approaches and sidewalks prior to starting construction or risk repairing at his cost.

03.2103 QUALITY ASSURANCE

- A. Testing and Inspection of Installation
 - 1. The City will inspect the installation. If any asphalt or concrete is found to not be installed adequately, the Contractor will be required to remove and replace promptly. Upon notifications from the contractor, the City will perform a re-inspection. Should additional asphalt be found to be unsatisfactorily installed, and additional inspections are required, these inspections shall be at Contractor's cost, at the discretion of the City.

END OF SECTION
032100

REPLACEMENT & INSTALLATION OF SIDEWALKS
SECTION 032200
TREES

03.2201 MATERIALS

- A. Live Oaks, Mahogany, Crape Myrtle, Silver Buttons shall be graded Florida #1 or better.
- B. Ten to Twelve foot (10' – 12') Oaks shall have a minimum spread of five foot (5') and a caliper of two inches (2").

03.2202 INSTALLATION

- A. Trees shall be installed in a straight line.
- B. Bottom of planting hole shall be scarified to a minimum depth of eight inches (8"), breakthrough and loosen all hardpan (remove if necessary to facilitate drainage).
- C. Set tree level with its original grade or slightly higher no more than 1" to 2".
- D. Backfill planting hole after tree is set with soil consisting of a homogeneous mixture of: 40% sand, 45% peat moss, 15% pine bark and mixed with: 50% with the excavated soil from the planting site.
- E. Tree shall be thoroughly watered in to eliminated any and all air pockets.
- F. A six inch (6") high rim of dirt shall be installed around excavated hole to form a saucer shape, which will hold water around the rootball.
- F. Fertilizer Agriform tablets 20-10-5, six (6) per tree shall be applied during backfilling of hole.
- H. A three (3") layer of mulch shall extend from the outside rim to the saucer to three inches (3") away from the base of the tree.

- I. Tree shall be braced using three (3) 2" x 4" x 8" stakes attached with black rubber hose ½" dia. tied with doublestrand 12 gauge galvanize wire.

03.2203 POST MAINTENANCE

- A. Contractor is responsible for all maintenance of the tree during the warranty period of the one-year. This includes but is not limited to: weeding, re-mulching, re-staking, pruning, (if required), retention saucer repair, etc.

END OF SECTION
032200

REPLACEMENT & INSTALLATION OF SIDEWALKS
SECTION 032300
IRRIGATION

03.2301 CONDITONS

- A. Contractor is responsible for identifying any irrigation piping that residents may have either in the swale or along the existing sidewalk. Any irrigation piping, sprinklers or wiring must be replaced and relocated when lines are encroaching into the ROW where new sidewalks are to be installed, to the residents' satisfaction.
- B. Contractor shall identify and document all locations and notify the City's authorize personnel of any existing irrigation systems. Documents will be used by the City's authorize personnel for inspection to verify satisfactory repairs or replacements.

03.2302 INSTALLATION

- A. Any piping that is removed shall be replaced with same diameter PVC. Schedule 40 PVC fittings shall be used.
- B. Sprinklers shall be new four inch (4") or less pop-up head with a maximum spray radius of fifteen (15') feet.

END OF SECTION
03230

REPLACEMENT & INSTALLATION OF SIDEWALKS
SECTION 032400
FENCING

03.2401 MATERIALS

- A. Chain link fabric – Shall be, steel No. 9 gauge wire woven, in a two inch diamond (2") mesh, hot dipped galvanized anchor fence with a zinc coating a minimum of 1.2 ounces per square foot complying with ASTM A-392. Weight of zinc coating shall be determined as defined in ASTM Designation A-90.
- B. Posts and Other Appurtenances - All posts and other appurtenances used in the construction of the fence shall be hot dipped galvanized with a minimum of 1.8 ounces per square foot of surface and black or green vinyl coated as noted above. Pipe sections shall conform to the requirements of ASTM Designation A-53. End, line and corner posts shall be two inch (2") O.D. pipe weighing 2.27 lbs. per linear foot.

- C. Railing- All railing inclusive of top, bottom and mid shall be 1-5/8" O.D. pipe weighting 1.43 lbs. per linear foot. Top rail shall be provided with couplings approximately every 20 feet. Couplings are to be outside sleeve type, at least six inches (6") long.
- D. Fittings - All fittings shall be galvanized malleable iron or pressed steel; all bands shall be beveled edged non-climbable type.

03.2402 CONDITONS

- A. Contractor is responsible for identifying any existing fencing that residents may have either in the swale or along the existing sidewalk. Any fencing must be relocated to the City's satisfaction.
- B. Contractor shall identify and document all locations and notify the City's authorize personnel of any existing fences. Documents will be used by the City's authorize personnel for inspection to verify satisfactory re-location.

03.2403 INSTALLATION

- A. Any fencing that is removed shall be replaced with like material or re-located in compliance with applicable codes and regulations. Shall include disposal of existing fencing and restoration that includes sod.
- B. Contractor shall adjust heights of existing fence gates when the sidewalk elevation conflicts with their use.

END OF SECTION
03240

REPLACEMENT & INSTALLATION OF SIDEWALKS
SECTION 03250
SIGN RELOCATION

03.2501 CONDITIONS

- A. Contractor is responsible for identifying any existing signs in right-of-way (ROW) that may be in conflict with installation of sidewalk.

03.1502 INSTALLATION

- A. These signs may include but not limited to: bus stop, regulatory or informational signs, stop signs, speed zone signs, etc. Any signs relocated must be pre-approved by City Engineer. Signs or facility that have electric are not part of this work.

END OF SECTION
03250

REPLACEMENT & INSTALLATION OF SIDEWALKS
SECTION 03260
PRESSURE CLEANING

03.2601 CONDITIONS

- A. Brick Pavers or Paver Blocks in area of replacement or installation of sidewalks may require pressure cleaning
- B. Existing concrete sidewalks in area of installation of sidewalks may require pressure cleaning

03.2602 INSTALLATION

- A. Pressure clean brick pavers or paver blocks to high quality-new new conditions, with no streaking to remove all dirt, mildew, stains (including oil), gum, tire/location marks, graffiti etc. Any voids to be filled with clean sand.
- B. Pressure clean brick pavers or paver blocks to high quality-new new conditions, with no streaking to remove all dirt, mildew, stains (including oil), gum, tire/location marks, graffiti etc. Any voids to be filled with clean sand. After Hours – 7:00 P.M. to 5:00 A.M. and weekends as per City Engineer request.
- C. Pressure clean concrete sidewalks to high quality-new new conditions, with no streaking to remove all dirt, mildew, stains (including oil), gum, tire/location marks, graffiti etc.
- D. Pressure clean concrete sidewalks to high quality-new new conditions, with no streaking to remove all dirt, mildew, stains (including oil), gum, tire/location marks, graffiti etc. After Hours – 7:00 P.M. to 5:00 A.M. and weekends as per City Engineer request.

Instructions for: 12' trees

NOTE:

TOP OF TREE BALL TO BE SET APPROX. 4" BELOW GRADE. SLOPE GRADE FROM APPROX. 24" OUTSIDE TREE BALL TO PROVIDE FOR THE WATER RETENTION BASIN.

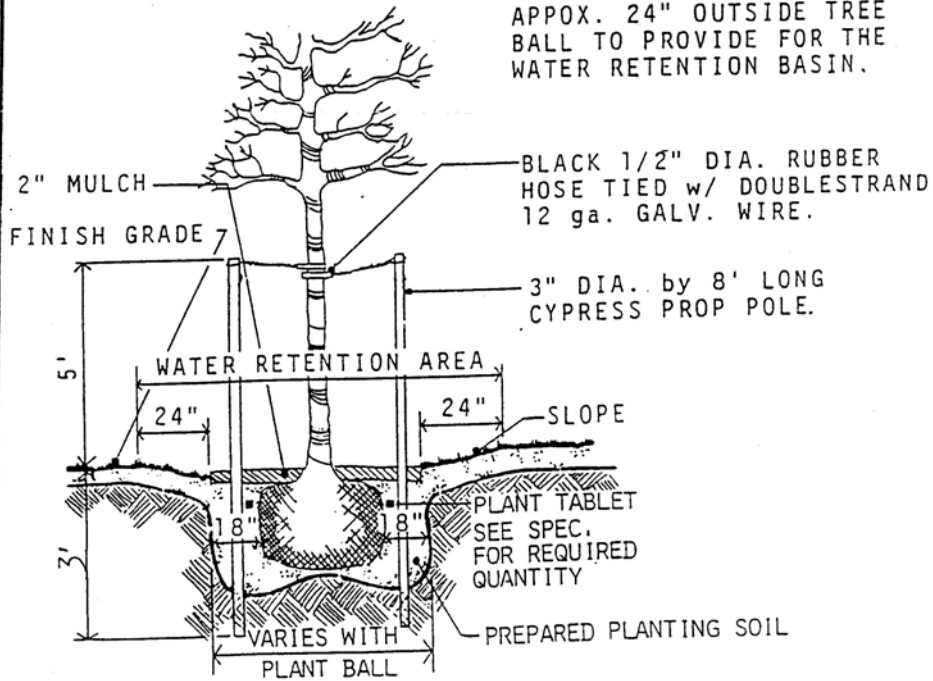

SECTION



PLANTING DETAIL - TREE WITH STAKES
1"-2" CALIPER

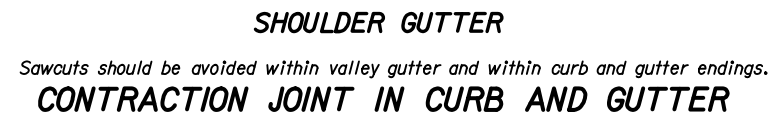
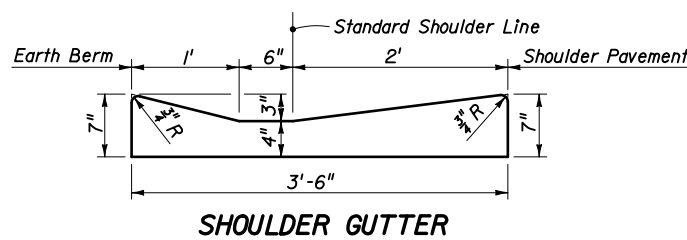
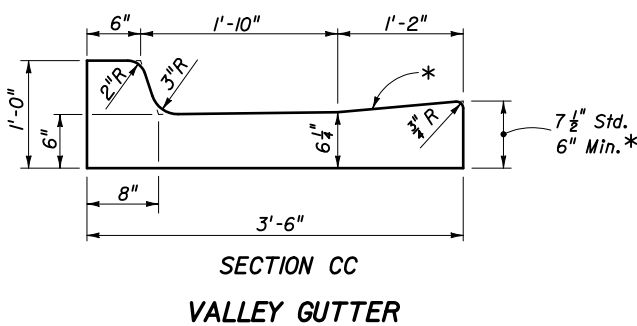
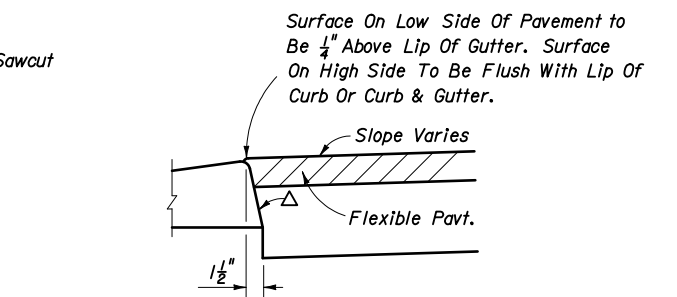
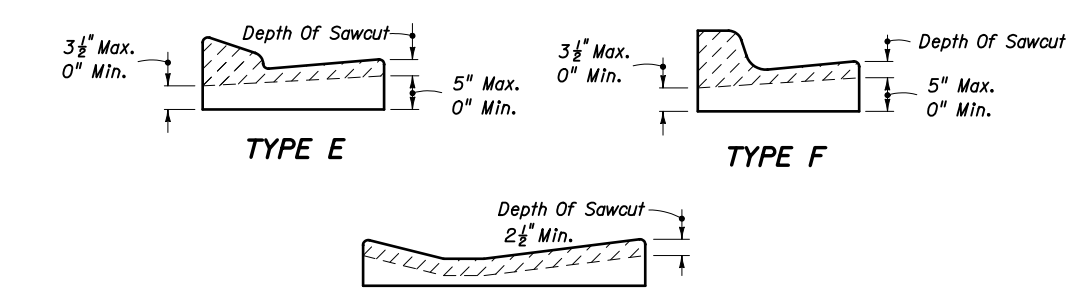
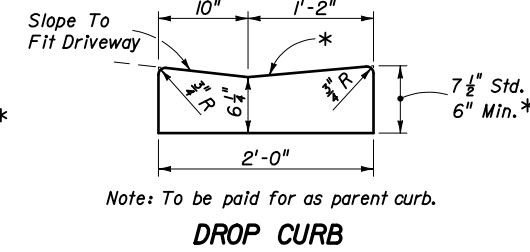
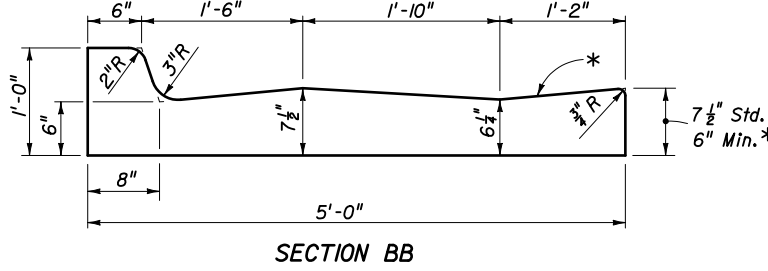
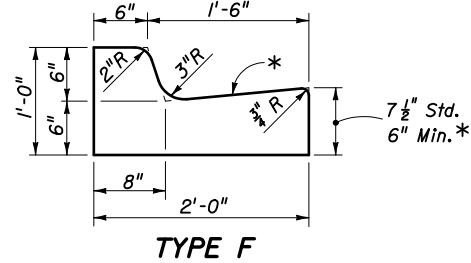
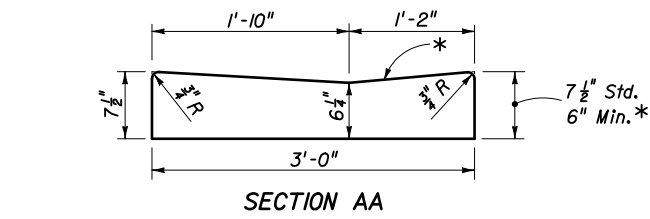
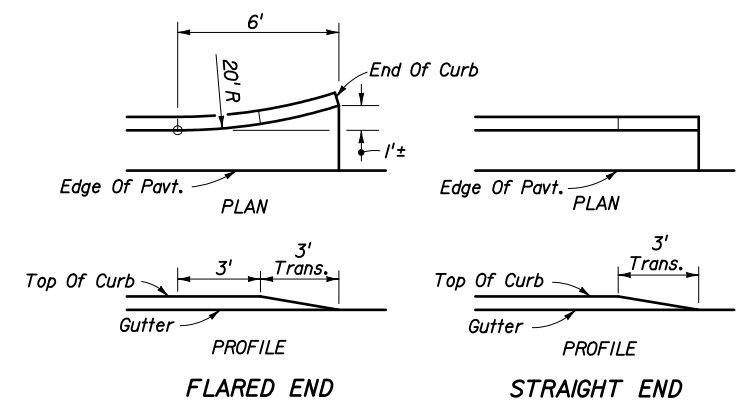
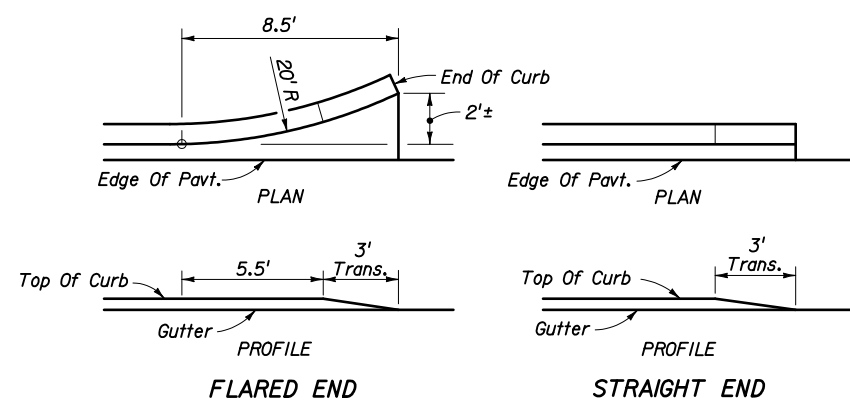
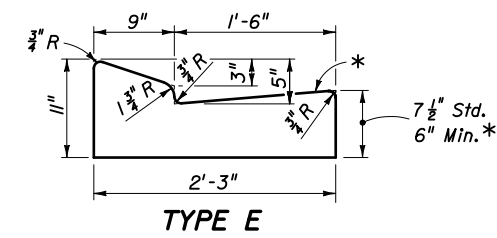
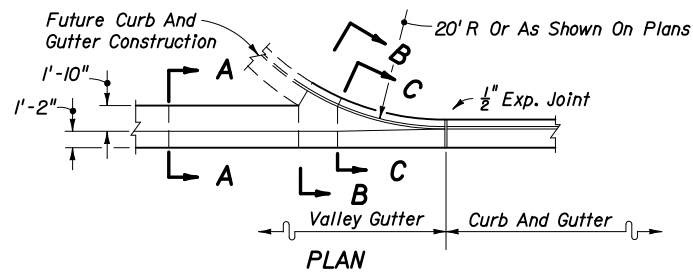

△ Applies to both high and low sides of pavement, low side shown. Applies to shoulder gutter only where adjoining traffic lanes.

CURB AND GUTTER AND TYPE A CURB ADJACENT TO FLEXIBLE PAVEMENT

* When used on high side of roadways, the cross slope of the gutter shall match the cross slope of the adjacent pavement. The thickness of the lip shall be 6", unless otherwise shown on plans.

■ Rotate entire section so that gutter cross slope matches slope of adjacent circulating roadway pavement.

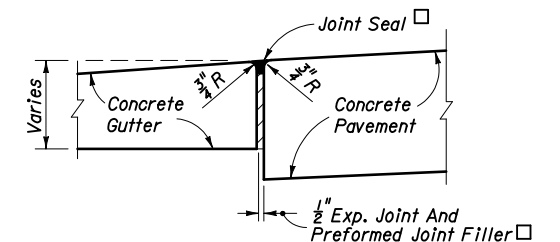
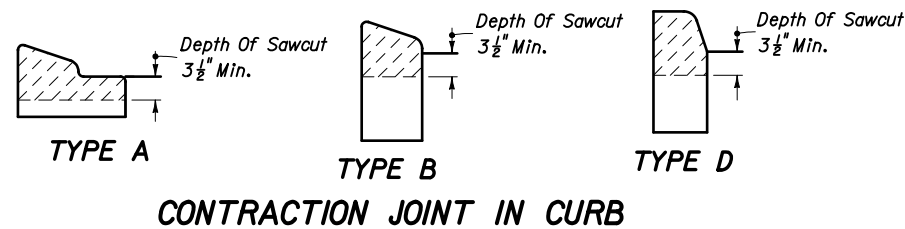
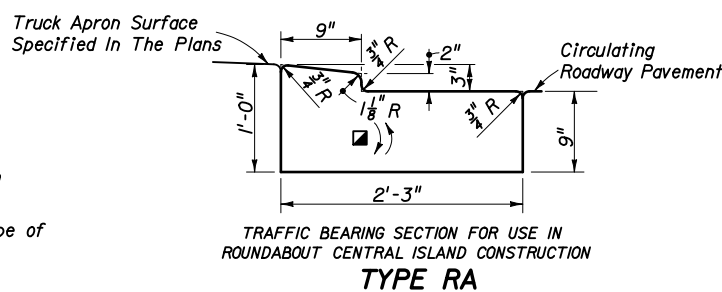

□ Applies to both high and low sides of pavement, low side shown.

EXPANSION JOINT BETWEEN GUTTER AND CONCRETE PAVEMENT

Note: For use adjacent to concrete or flexible pavement. For details depicting usage adjacent to flexible pavement, see diagram right. Expansion joint, preformed joint filler and joint seal are required between curb & gutter and concrete pavement only, see diagram right.

CONCRETE CURB AND GUTTER

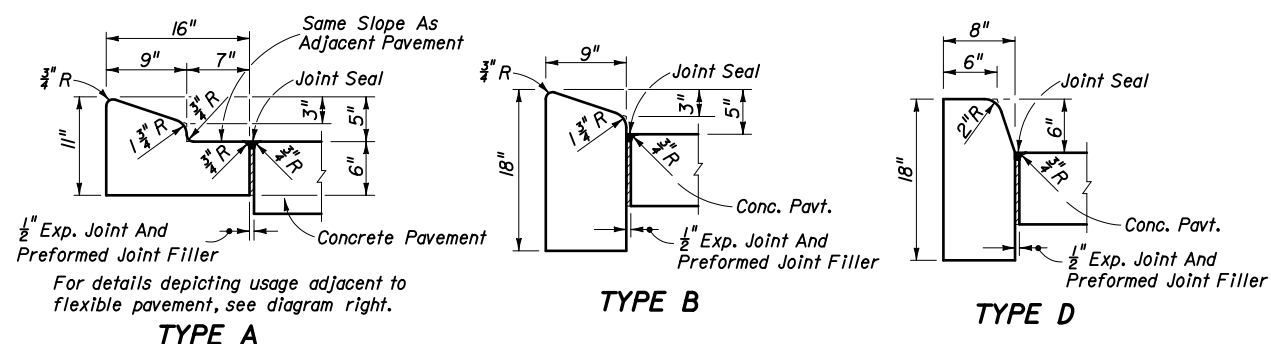

For details depicting usage adjacent to flexible pavement, see diagram right.

TYPE A

TYPE B

TYPE D

Note: For use adjacent to concrete or flexible pavement, concrete shown. Expansion joint, preformed joint filler and joint seal are required between curbs and concrete pavement only, see diagram right.

CONCRETE CURB

ASPHALTIC CONCRETE CURB

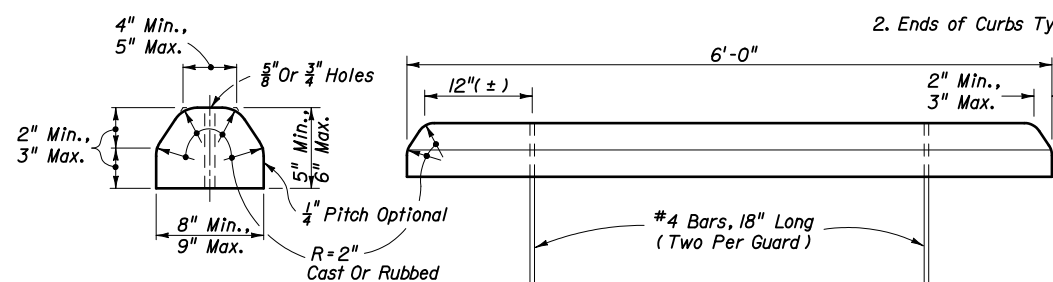

CONCRETE BUMPER GUARD

GENERAL NOTES

1. For curb, gutter and curb & gutter provide 1/8" - 1/4" contraction joints at 10' centers (max.). Contraction joints adjacent to concrete pavement on tangents and flat curves are to match the pavement joints, with intermediate joints not to exceed 10' centers. Curb, gutter and curb & gutter expansion joints shall be located in accordance with Section 520 of the standard specifications.
2. Ends of Curbs Types B and D shall transition from full to zero heights in 3'.

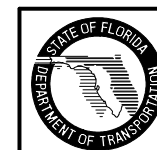

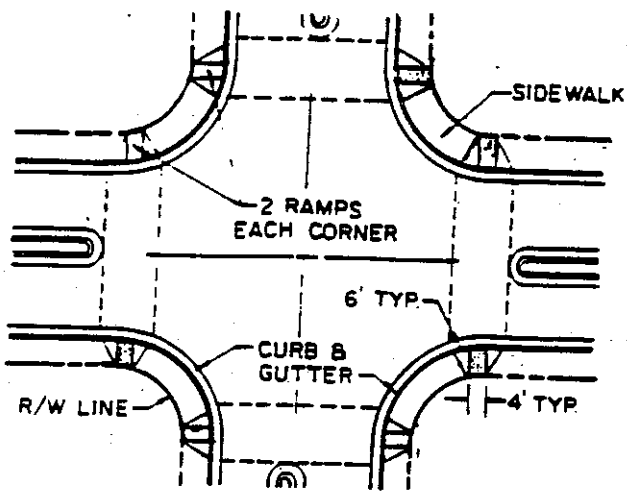

**2 MAJOR ROADWAYS
(CURB & GUTTER)**

REF: Sec. 2a (1)(a)*

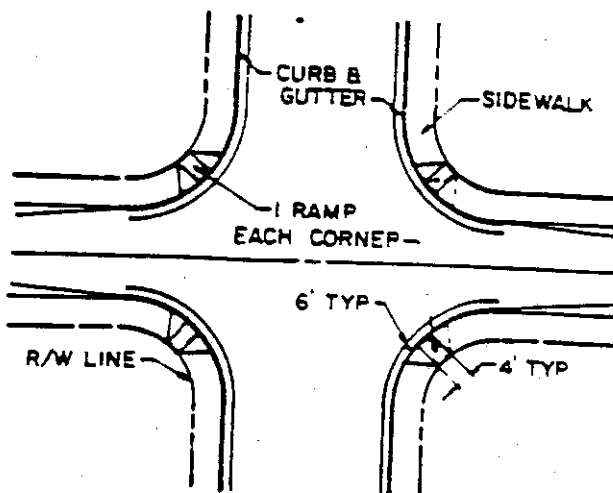

**LOCAL ROADWAY OR ENTRANCE
TO MAJOR SHOPPING CENTER
(CURB & GUTTER)**

REF: Sec. 2a (1)(b)*

**ROADWAY
INTERSECTIONS**

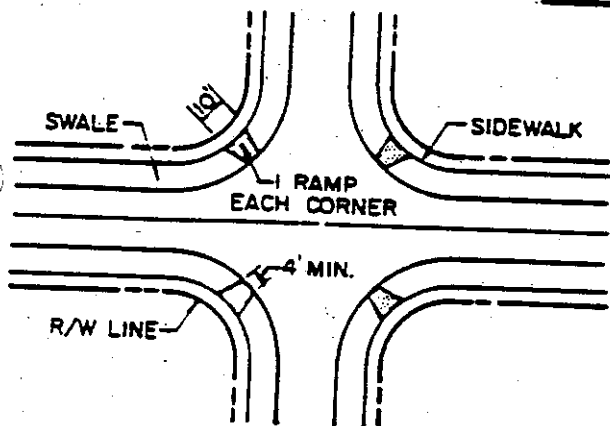

(RESIDENTIAL ROADWAYS)

**2 MAJOR ROADS, LOCAL & MAJOR
ROADWAY, & 2 LOCAL ROADWAYS
(SWALE)****

REF: Sec. 2b (1)*

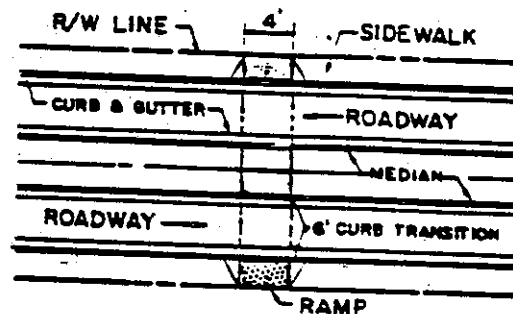

**MID-BLOCK AT NORMAL
PEDESTRIAN CROSSING
(SWALE or CURB & GUTTER)****

REF: Sec. 2a (2)*

NOTES

1. Max. slope of ramps = 12:1 (for sidewalk widths greater than or equal to 6'-0").
2. Ramps may be 4" thick in residential areas.
3. Colors: All pedestrian ramps shall contrast visually with adjoining sidewalk surfaces. (i.e., locations within Dade Co. and outside of Coral Gables shall be integral colored "Coral Gables Beige".) Pedestrian ramps within Coral Gables, Miami Beach, and Key Biscayne shall have no color additive. All other construction (i.e., sidewalk, connections, etc.) shall match the adjoining sidewalk or.

** Alternate asph. conc. sidewalk ramp (same thickness), may be used as approved by Director of Public Works Department.

* For all references, see Dade County Public Works Department "Policy on pedestrian ramps in Public Rights-Of-Way".

CURB & GUTTER	R 15.2	
ASPH. CONC. S. COURSE		SEC. 133
CONC. DRIVEWAY	R 12.6	
CONC. SIDEWALK	R-13.1	SEC. 145
ITEM	CROSS REF.	SPEC. REF.

METROPOLITAN
DADE COUNTY
PUBLIC WORKS
DEPARTMENT

APPROVED
9/15/72

REVISED

4/5/74

6/4/86

STANDARD ROAD DETAIL
PEDESTRIAN RAMPS
IN PUBLIC RIGHTS-OF-WAY

**R
13.3**

METROPOLITAN
DADE COUNTY
PUBLIC WORKS
DEPARTMENT

APPROVED
6/5/61

REVISED
5/17/72
2/22/77

STANDARD ROAD DETAIL
SIDEWALK CONSTRUCTION

R
13.1
SHEET 1 OF 1

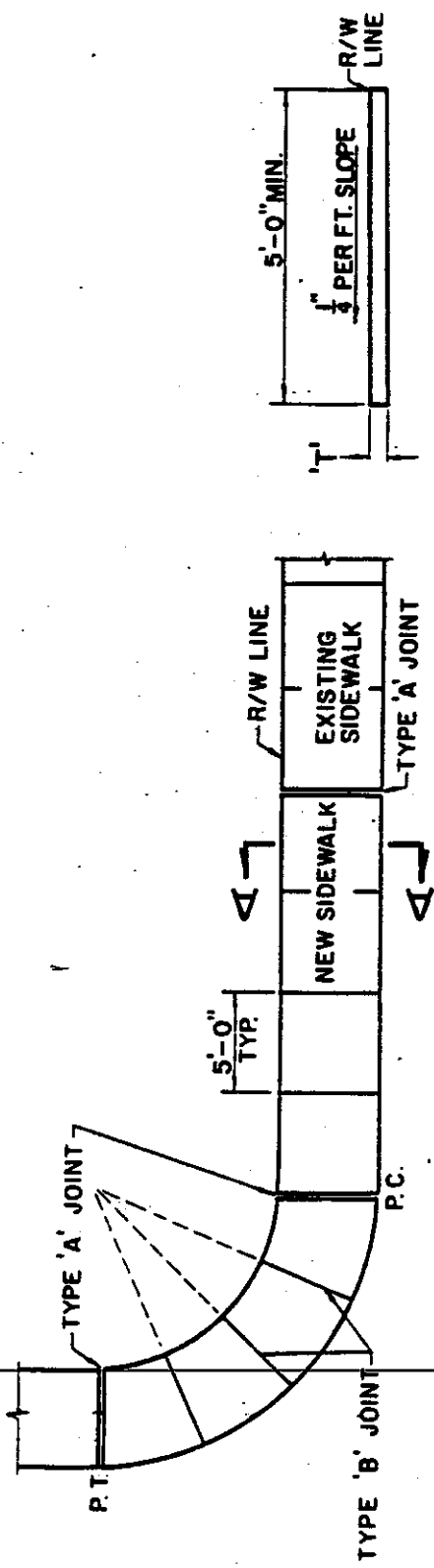

SECTION A-A

PLAN

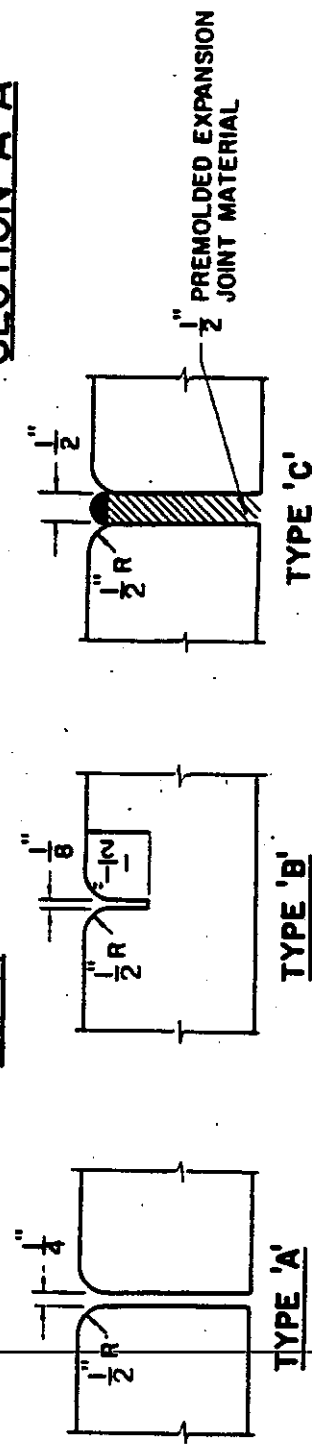

SIDEWALK JOINTS

TABLE OF SIDEWALK THICKNESS - 'T'	
LOCATION	'T'
RESIDENTIAL AREAS	4"
AT DRIVEWAYS AND OTHER AREAS	6"

TABLE OF SIDEWALK JOINTS	
TYPE	LOCATION
'A'	P.C. AND P.T. OF CURVES. JUNCTION OF EXISTING AND NEW SIDEWALKS.
'B'	5'-0" CENTER TO CENTER ON SIDEWALKS.
'C'	WHERE SIDEWALK ABUTS CONCRETE CURBS, DRIVEWAYS, AND SIMILAR STRUCTURES.

ITEM	CROSS REF.	SPEC. REF.
ST. INTERSECTION C&G CONC. SIDEWALK	R-152	SEC 145

BID FORM

PROJECT: REPLACEMENT & INSTALLATION OF SIDEWALKS
 CITY OF MIAMI GARDENS
 ITB #-09-10-069 – August 5,2010

BID SUBMITTED TO: CITY OF MIAMI GARDENS
 1515 NW 167TH Street #200
 Miami Gardens, Florida 33169

BID SUBMITTED BY: _____

 Phone _____ Fax _____
 E-Mail: _____

Items	Price per UOM	Est. Quantity	Total
Bonds Projects > \$150,000	\$		
Furnish all materials, labor & equipment to <u>Remove to be saw-cut & Replace 4" thick 3000 PSI min. un-reinforced sidewalk & compact 95% min. (includes restoration-clean fill to avoid gaps) damaged sod replaced at Contractor's expense</u>	\$ Sq. Ft.	73,000	
Furnish all materials, labor & equipment to <u>Remove to be saw-cut & Replace 6" thick 3000 PSI min. un-reinforced sidewalk & compact 95% min. (includes restoration-clean fill to avoid gaps) damaged sod replaced at Contractor's expense</u>	\$ Sq. Ft.	16,500	
Furnish all materials, labor & equipment <u>Install New 4" thick 3000 PSI min. un-reinforced sidewalk & compact 95% min.(includes clearing & grubbing, removal & disposal of dirt, grass etc. & restoration at Contractor's expense) damaged sod replaced at Contractor's expense</u>	\$ Sq. Ft.	39,000	
Furnish all materials, labor & equipment <u>Install New 6" thick 3000 PSI min. un-reinforced sidewalk & compact 95% min.(includes clearing & grubbing, removal & disposal of dirt, grass etc. & restoration at Contractor's expense) damaged sod replaced at Contractor's expense</u>	\$ Sq. Ft.	5,000	
Furnish & Compact Lime Rock to min. 95% to avoid settling. When elevation is too low. Fill any gaps between new sidewalk	\$ Cubic Yd	100	

installation and existing elevation. Delivery ticket must be provided for payment			
Furnish all materials, labor & equipment to <u>Remove & Replace concrete Type "D" Curb</u> including drop curb, transitions, & reconstruction of base (includes clearing & grubbing, removal & disposal of existing curb, dirt, grass etc. & restoration at Contractor's expense including fill) damaged sod replaced at Contractor's expense	\$	Linear Ft.	250
Furnish all materials, labor & equipment to <u>Remove & Replace concrete Type "F" Curb</u> including drop curb, transitions, & reconstruction of base (includes clearing & grubbing, removal & disposal of existing curb, dirt, grass etc. & restoration at Contractor's expense including fill) damaged sod replaced at Contractor's expense	\$	Linear Ft.	1,725
Furnish all materials, labor & equipment to <u>Remove & Replace concrete "Valley-gutter"</u> including drop curb, transitions, & reconstruction of base (includes clearing & grubbing, removal & disposal of existing curb, dirt, grass etc. & restoration at Contractor's expense including fill) damaged sod replaced at Contractor's expense	\$	Linear Ft.	3,000
Right-of- Way Survey (to establish property lines)	\$	Linear Ft.	3,000
Furnish all materials, labor & equipment to Trim, Tree Root Pruning/Biobarrier (includes restoration - clearing & grubbing, removal of debris, excavation & backfilling) damaged sod replaced at Contractor's expense	\$	Per tree	125
Tree Removal			
Dia. @ breast hgt.4.5' above grade 0 to 8"	\$	Per tree	10
Cont. 8"+ to 18"	\$	Per tree	10
18"+ to 30"	\$	Per tree	20
30" +	\$	Per tree	20
(includes restoration - clearing & grubbing, removal of debris, excavation & backfilling) damaged sod replaced at Contractor's expense			Sub-TOTAL
Live Oak Fla. #1 10'-12' overall height (includes restoration - clearing & grubbing,	\$	Per tree	15

removal of debris, excavation & backfilling) damaged sod replaced at Contractor's expense			
Mahogany Fla. #1 10'-12' overall height (includes restoration - clearing & grubbing, removal of debris, excavation & backfilling) damaged sod replaced at Contractor's expense	\$	Per tree	10
Crape Myrtle Fla. #1 10'-12' overall height (includes restoration - clearing & grubbing, removal of debris, excavation & backfilling) damaged sod replaced at Contractor's expense	\$	Per tree	10
Curb Cuts (inc. restoration)	\$	Each	510
Furnish all materials, labor & equipment to <u>Relocate Chain Link Fence</u> (includes restoration) damaged sod replaced at Contractor's expense	\$	Linear Ft.	100
Furnish all materials, labor & equipment to <u>Install New 4' Chain Link Fence, disposal of existing fence</u> (includes restoration) damaged sod replaced at Contractor's expense	\$	Linear Ft.	100
Furnish all materials, labor & equipment to construct <u>1" Type III Asphaltic Concrete</u> surface including Tack Coat to repair existing driveway approaches. Damaged areas during installation replaced at Contractor's expense	\$	Sq. Ft.	500
Furnish all materials, labor & equipment to place Detectable Warning Surface for pedestrian crossings/ <u>cast-in-place</u> type/yellow	\$	Sq. Ft.	200
Furnish all materials, labor & equipment to place Detectable Warning Surface for pedestrian crossings <u>replaceable</u> type/yellow	\$	Sq. Ft.	200
Furnish all materials, labor & equipment to Relocate PVC Lines – 2" diameter	\$	Linear Ft.	300
Furnish all materials, labor & equipment to Install new PVC Lines Sch. 40	\$	Linear Ft.	300
Furnish all materials, labor & equipment to Install new Irrigation Heads (4" pop-up head w/max 15' spray radius)	\$	Each	40
Furnish all materials, labor & equipment to Relocate/reset existing Signs	\$	Each	20
Compaction Test	\$	Each	50

Furnish all materials, labor & equipment to Raise Utilities Access (includes sewer cleanouts, water meters, manholes, water valves)	\$	Each	50	
Furnish all materials, labor & equipment to Pressure clean Brick Pavers & Paver Blocks	\$	Sq. Ft.	500	
Furnish all materials, labor & equipment to Pressure clean Brick Pavers & Paver Blocks Nights & Weekends	\$	Sq. Ft.	500	
Furnish all materials, labor & equipment to Pressure clean Concrete Sidewalks	\$	Sq. Ft.	1,000	
Furnish all materials, labor & equipment to Pressure clean Concrete Sidewalks Nights & Weekends	\$	Sq. Ft.	1,000	
Furnish all materials, labor & equipment to install St. Augustine "Floritam" or Bahia sod on areas authorized by City. (includes grading, clearing, grubbing & disposal of material) This item is <u>not</u> for Damaged areas during installation by Contractor	\$	Sq. Ft.	1,000	

The above proposals and each line item includes the total cost to complete the Work detailed for each item including but not limited to materials (i.e. vegetation, concrete, asphalt, etc.), labor, equipment, bonds, etc. indicated in the drawings, specifications, addenda, and any other contract documents.

I. NOTES TO BIDDERS:

1. Bidder shall fill in the entire Bid Form, No spaces are to be left blank.
2. The City reserves the right to utilize any combination of the base proposals, as they so desire to achieve the proper balance between the required improvements, desired improvements, and City's available project budget.
3. The City reserves the right to request per unit/each pricing of materials listed on the bid form for clarification or to purchase additional materials.
4. Contractor shall indicate if willing to accept VISA purchase card as payment
_____ **Yes** _____ **No**

II. BIDDER'S REPRESENTATION

1. The undersigned BIDDER proposes and agrees, if this Proposal is accepted, to enter into an agreement with CITY to perform and furnish all Work as specified or indicated in the Bid Documents for the Proposed price and within the Bid times indicated in this Proposal and in accordance with the other terms and conditions of the Documents.

2. BIDDER accepts all of the terms and conditions of the Advertisement or Invitation To Bid and General/Special Conditions, including without limitation those dealing with disposition of Proposal security. This Proposal will remain subject to acceptance for ninety (90) days after the day of Bid opening.

3. In submitting this Bid, BIDDER represents, as more fully set forth in the Documents that:

(A) BIDDER has examined and carefully studied the Bid Documents and the following Addenda receipt of all which is hereby acknowledged: (List Addenda by Addendum Number and Date)

(B) BIDDER is familiar with and is satisfied as to all federal, state and local Laws and Regulations that may affect cost, progress, performance and furnishing of the Work.

(C) BIDDER has given CITY'S Purchasing Manager written notice of all conflicts, errors, ambiguities or discrepancies that BIDDER has discovered in the Documents and the written resolution thereof by CITY is acceptable to BIDDER, and the Documents are generally sufficient to indicate and convey understanding of all terms and conditions for performing and furnishing the Work for which this Proposal is submitted.

(D) This Proposal is genuine and not made in the interest or on behalf of any undisclosed person, firm or corporation and is not submitted in conformity with any agreement or rules of any group, association, organization or corporation; BIDDER has not directly or indirectly induced or solicited any other BIDDER to submit a false or sham Proposal; BIDDER has not solicited or induced any person, firm or corporation to refrain from bidding; and BIDDER has not sought by collusion to obtain for itself any advantage over any other BIDDER or over CITY.

4. BIDDER agrees that the Work: will be substantially complete per schedule within the Documents and completed and ready for final payment in accordance with the Documents within agreed upon, per each task order, in consecutive calendar days.

5. The following documents are attached to and made a condition of this Proposal:

- (A) A tabulation of Subcontractors, Suppliers, if applicable and other persons and organizations required to be identified in this Proposal
- (B) Required CONTRACTOR'S Qualification Statement with support data

- (C) Statement of BIDDER'S experience
- (D) References, Insurance Certificates, Licenses
- (E) Drug Free Work Place
- (F) W-9 Form

6. Communications concerning this Bid shall be addressed to:
 The address of BIDDER indicated below
 The following address:

7. Terms used in this Bid which are defined in the General Conditions or Instructions will have the meanings indicated in the General Conditions or Instructions

SUBMITTED on _____, 2010

State CONTRACTOR License No. _____

If BIDDER is:

An Individual

By _____ (SEAL)
 (Individual's Name)

doing business as _____
 Business address _____

Phone & Fax No. P _____ F _____

E-mail Address: _____

A Partnership

By _____ (SEAL)
 (Firm Name)

_____ (General Partner)

Business address _____

Phone & Fax No. P _____ F _____

E-mail Address: _____

A Corporation

By _____ (SEAL)
 (Corporation Name)

_____ (State of Incorporation)

By _____
 (Name of Person Authorized to Sign)

(Title)

(Corporate Seal)

Attest:

(Secretary)

Business address

Phone & Fax No.

P _____ F _____

E-mail Address:

Date of Qualifications to do business is

A Joint Venture

By

(Name)

(Address)

By

_____ (SEAL)

(Name)

(Address)

Phone & Fax number and Address for receipt of official communications

(Each joint venturer must sign. The manner of signing for each individual, partnership and corporation that is a party to the joint venture should be in manner indicated above)

How did you learn about this solicitation?

Daily Business Review _____

City's Web Site _____

DemandStar _____

Other, please list _____

DRUG FREE WORKPLACE

Preference shall be given to businesses with drug-free workplace programs. Whenever two or more Bids which are equal with respect to price, quality, and service from businesses that are not located within the City of Miami Gardens are received by the City for the procurement of commodities or contractual services, a Bid received from a business that certifies that it has implemented a drug-free workplace program shall be given preference in the award process. In order to have a drug-free workplace program, a business shall:

1. Publish a statement notifying employees that the unlawful manufacture, distribution, dispensing, possession, or use of a controlled substance is prohibited in the workplace and specifying the actions that will be taken against employees for violations of such prohibition.
2. Inform employees about the dangers of drug abuse in the workplace, the business's policy of maintaining a drug-free workplace, any available drug counseling, rehabilitation, and employee assistance programs, and the penalties that may be imposed upon employees for drug abuse violations.
3. Give each employee engaged in providing the commodities or contractual services that are under Bid a copy of the statement specified in subsection (1).
4. In the statement specified in subsection (1), notify the employees that, as a condition of working on the commodities or contractual services that are under Bid, the employee will abide by the terms of the statement and will notify the employer of any conviction of, or plea of guilty or nolo contendere to, any violation of chapter 893 or of any controlled substance law of the United States or any state, for a violation occurring in the workplace no later than five (5) days after such conviction.
5. Impose a sanction on, or require the satisfactory participation in a drug abuse assistance or rehabilitation program if such is available in the employee's community, by any employee who is so convicted.
6. Make a good faith effort to continue to maintain a drug-free workplace through implementation of this section.

As the person authorized to sign the statement, I certify that this firm complies fully with the above requirements.

Vendor's Signature

PROJECT: REPLACEMENT & INSTALLATION OF SIDEWALKS

OWNER: CITY OF MIAMI GARDENS

BIDDER:

INSTRUCTIONS

- A. All questions are to be answered in full, without exception. If copies of other documents will answer the question completely, they may be attached and clearly labeled. If additional space is needed, additional pages may be attached and clearly labeled.
- B. The City of Miami Gardens shall be entitled to contact each and every person/company listed in response to this questionnaire. The bidder, by completing this questionnaire, expressly agrees that any information concerning the bidder in possession of said entities may be made available to the City.
- C. Only complete and accurate information shall be provided by the bidder. The bidder hereby warrants that, to the best of its knowledge and belief, the responses contained herein are true, accurate, and complete. The bidder also acknowledges that the City is relying on the truth and accuracy of the responses contained herein. If it is later discovered that any material information given in response to a questions was provided by the bidder, knowing it was false, it shall constitute grounds for immediate disqualification, termination, or rescission by the City of any subsequent agreement between the City and the bidder.
- D. If there are any questions concerning the completion of this form, the bidder is encouraged to contact Pam Thompson, CPPO, Procurement Manager, facsimile: (305) 474-1285, e-mail: pthompson@miamigardens-fl.gov.

QUESTIONNAIRE

Proposer's Name: _____

Principal Office Address: _____

Official Representative: _____
Individual
Partnership (Circle One)
Corporation

If a Corporation, answer this:

When Incorporated:

In what State: _____

If Foreign Corporation:

Date of Registration with
Florida Secretary of State: _____

Name of Resident Agent: _____

Address of Resident Agent: _____

President's Name: _____

Vice President's Name: _____

Treasurer's Name: _____

Members of Board of Directors:

If a Partnership:

Date of Organization: _____

General or Limited Partnership*: _____

Name and Address of Each Partner:

Name

Address

1. _____

2. _____

3. _____

*Designate general partners in Limited Partnership

1. Number of years of relevant experience in operating similar business: _____

2. Have any similar agreements held by proposer for a similar project to the proposed project ever been canceled?

Yes ()

No ()

If yes, give details on a separate sheet.

3. Has the proposer or any principals of the applicant organization failed to qualify as a responsible proposer, refused to enter into a contract after an award has been made, failed to complete a contract during the past five (5) years, or been declared to be in default in any contract in the last five (5) years?

If yes, please explain:

4. Has the proposer or any of its principals ever been declared bankrupt or reorganized under Chapter 11 or put into receivership?

If yes, give date, court jurisdiction, action taken, and any other explanation deemed necessary.

5. Person or persons interested in the proposal and Questionnaire Form _____ (have) _____ (have not) been convicted by a Federal, State, County or Municipal Court of any violation of law, other than traffic violations. To include stockholders over ten percent (10%). (Strike our inappropriate words).

Explain any convictions on a separate sheet.

6. Lawsuits (any) pending or completed involving the corporation, partnership or individuals with more than ten percent (10%) interest:
 - A. List all pending lawsuits:
 - B. List all completed lawsuits:
 - C. List all judgments from lawsuits in the last five years:
 - D. List any criminal violations and/or convictions of the proposer and/or any of its principals:
7. Conflicts of Interest. The following relationships are the only potential, actual or perceived conflicts of interest in connection with this proposal: (If none, so state).
8. List the work you will perform with your own forces on this project: List any Sub-Contractors for this project:

The proposer understands that information contained in this Questionnaire will be relied upon by the City of Miami Gardens in awarding the proposed Agreement and such information is warranted by the proposer to be true. The undersigned proposer agrees to furnish such additional information, prior to acceptance of any proposal relating to the qualifications of the proposer, as may be required by the City Manager.

The proposer further understands that the information contained in this questionnaire may be confirmed through a background investigation conducted by the Miami Gardens Police Department. By submitting this questionnaire, the proposer agrees to cooperate with this investigation, including but not necessarily limited to fingerprinting and providing information for credit check.

I certify that the information and responses provided on this Questionnaire are true, accurate and complete. The Owner of the Project or its representatives may contact any entity or reference listed in this Questionnaire. Each entity or reference may make any information concerning the Contractor available to the Owner.

Dated _____, **20**__

INDIVIDUAL, FIRM OR PARTNERSHIP

By: _____ / _____
(Signature) (Print name)

Address: _____

Telephone: (____) _____ Fax: (____) _____
E-Mail: _____

Social Security Number (OR) Taxpayer Identification Number (TIN): _____

CORPORATION

By: _____ / _____
(Signature) (Print name)

Address: _____

Telephone: (____) _____ Fax: (____) _____
E-Mail: _____

Taxpayer Identification Number (TIN/EIN): _____

State Under Which Corporation Was Chartered: _____

Corporate President: _____
(Print Name)

Corporate Secretary: _____
(Print Name)

Corporate Treasurer: _____
(Print Name)

CORPORATE SEAL

Attest By: _____
Secretary

REFERENCES

As specified in the Special Conditions of this Bid Document, Bidders are to present the details of a minimum of five (5) references of similar work. (Additional references may be submitted on a separate sheet)

COMPANY NAME, ADDRESS, CITY, STATE, ZIP E-MAIL ADDRESS & FAX NUMBER	
Company Name:	
Address:	
Contact Name:	
E-Mail:	Fax:
Company Name:	
Address:	
Contact Name:	
E-Mail:	Fax:
Company Name:	
Address:	
Contact Name:	
E-Mail:	Fax:
Company Name:	
Address:	
Contact Name:	
E-Mail:	Fax:

**LIST OF EQUIPMENT AVAILABLE
FOR THIS CONTRACT**

List all equipment which will be dedicated to the Lot Clearing Services as listed in this bid document.
(Additional equipment may be submitted on a separate sheet in this format)

EQUIPMENT	NUMBER AVAILABLE	EMPLOYEES & EXPERIENCE ASSIGNED TO OPERATE THIS EQUIPMENT
1.		
2.		
3.		
4.		
5.		
6.		
7.		
8.		
9.		
10.		

LIST OF SUBCONTRACTORS

The Undersigned states that the following is a full and complete list of the proposed subcontractors on this Project and the class of Work to be performed by each, and that such list will not be added to nor altered without written consent to the City through the City Representative.

SUBCONTRACTOR AND ADDRESS

CLASS OF WORK TO BE PERFORMED

(1) _____

(2) _____

(3) _____

(4) _____

(5) _____

(6) _____

(7) _____

DATE

PROPOSER

BY: _____

Request for Taxpayer Identification Number and Certification

**Give form to the
requester. Do not
send to the IRS.**

Print or type
See Specific Instructions on page 2.

Name (as shown on your income tax return)	
Business name, if different from above	
Check appropriate box: <input type="checkbox"/> Individual/Sole proprietor <input type="checkbox"/> Corporation <input type="checkbox"/> Partnership <input type="checkbox"/> Limited liability company. Enter the tax classification (D=disregarded entity, C=corporation, P=partnership) ▶ <input type="checkbox"/> Exempt payee <input type="checkbox"/> Other (see instructions) ▶	
Address (number, street, and apt. or suite no.)	Requester's name and address (optional)
City, state, and ZIP code	
List account number(s) here (optional)	

Part I Taxpayer Identification Number (TIN)

Enter your TIN in the appropriate box. The TIN provided must match the name given on Line 1 to avoid backup withholding. For individuals, this is your social security number (SSN). However, for a resident alien, sole proprietor, or disregarded entity, see the Part I instructions on page 3. For other entities, it is your employer identification number (EIN). If you do not have a number, see *How to get a TIN* on page 3.

Social security number
or
Employer identification number

Note. If the account is in more than one name, see the chart on page 4 for guidelines on whose number to enter.

Part II Certification

Under penalties of perjury, I certify that:

1. The number shown on this form is my correct taxpayer identification number (or I am waiting for a number to be issued to me), and
2. I am not subject to backup withholding because: (a) I am exempt from backup withholding, or (b) I have not been notified by the Internal Revenue Service (IRS) that I am subject to backup withholding as a result of a failure to report all interest or dividends, or (c) the IRS has notified me that I am no longer subject to backup withholding, and
3. I am a U.S. citizen or other U.S. person (defined below).

Certification instructions. You must cross out item 2 above if you have been notified by the IRS that you are currently subject to backup withholding because you have failed to report all interest and dividends on your tax return. For real estate transactions, item 2 does not apply. For mortgage interest paid, acquisition or abandonment of secured property, cancellation of debt, contributions to an individual retirement arrangement (IRA), and generally, payments other than interest and dividends, you are not required to sign the Certification, but you must provide your correct TIN. See the instructions on page 4.

Sign Here	Signature of U.S. person ▶	Date ▶
------------------	----------------------------	--------

General Instructions

Section references are to the Internal Revenue Code unless otherwise noted.

Purpose of Form

A person who is required to file an information return with the IRS must obtain your correct taxpayer identification number (TIN) to report, for example, income paid to you, real estate transactions, mortgage interest you paid, acquisition or abandonment of secured property, cancellation of debt, or contributions you made to an IRA.

Use Form W-9 only if you are a U.S. person (including a resident alien), to provide your correct TIN to the person requesting it (the requester) and, when applicable, to:

1. Certify that the TIN you are giving is correct (or you are waiting for a number to be issued),
2. Certify that you are not subject to backup withholding, or
3. Claim exemption from backup withholding if you are a U.S. exempt payee. If applicable, you are also certifying that as a U.S. person, your allocable share of any partnership income from a U.S. trade or business is not subject to the withholding tax on foreign partners' share of effectively connected income.

Note. If a requester gives you a form other than Form W-9 to request your TIN, you must use the requester's form if it is substantially similar to this Form W-9.

Definition of a U.S. person. For federal tax purposes, you are considered a U.S. person if you are:

- An individual who is a U.S. citizen or U.S. resident alien,
- A partnership, corporation, company, or association created or organized in the United States or under the laws of the United States,
- An estate (other than a foreign estate), or
- A domestic trust (as defined in Regulations section 301.7701-7).

Special rules for partnerships. Partnerships that conduct a trade or business in the United States are generally required to pay a withholding tax on any foreign partners' share of income from such business. Further, in certain cases where a Form W-9 has not been received, a partnership is required to presume that a partner is a foreign person, and pay the withholding tax. Therefore, if you are a U.S. person that is a partner in a partnership conducting a trade or business in the United States, provide Form W-9 to the partnership to establish your U.S. status and avoid withholding on your share of partnership income.

The person who gives Form W-9 to the partnership for purposes of establishing its U.S. status and avoiding withholding on its allocable share of net income from the partnership conducting a trade or business in the United States is in the following cases:

- The U.S. owner of a disregarded entity and not the entity,